

VEGA 23:1

PNEUMATIC MIST-LESS PISTON PUMP

A T E X C E R T I F I E D
Ex II 2 G c IIB T4

**OPERATING AND
MAINTENANCE INSTRUCTION**

Version
on **TANK**



TROLLEY
Version



WALL BRACKET
Version

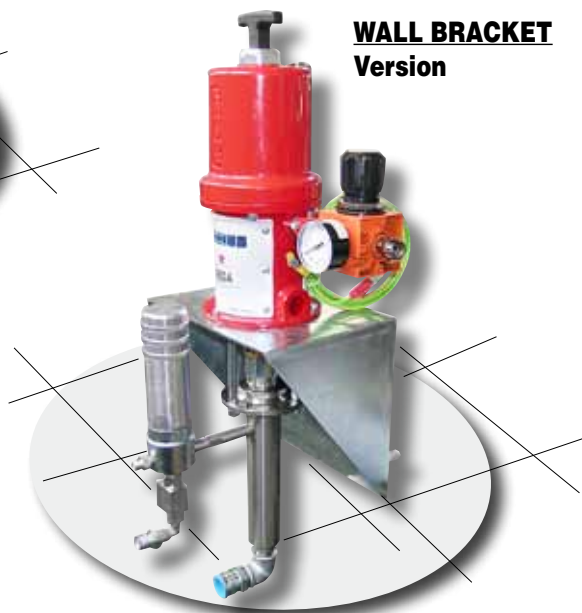

LARIUS[®]
PAINT SPRAYING EQUIPMENT

ENGLISH



Due to a constant product improvement programme, the factory reserves the right to modify technical details mentioned in this manual without prior notice.

This manual is to be considered as an English language translation of the original manual in Italian. The manufacturer shall bear no responsibility for any damages or inconveniences that may arise due to the incorrect translation of the instructions contained within the original manual in Italian.

**WE RECOMMEND THE USE OF THIS EQUIPMENT ONLY BY PROFESSIONAL OPERATORS.
USE THIS MACHINE FOR PURPOSES SPECIFICALLY MENTIONED IN THIS MANUAL, ONLY.**

Thank you for choosing a **LARIUS S.R.L.** product. As well as the purchased product, you will receive a range of support services enabling you to achieve the results desired in a quick and professional way.

LARIUS®

PNEUMATIC PISTON PUMP

INDEX.....	p. 1	N TROUBLESHOOTING.....	p.23
WARNINGS.....	p. 2	SPARE PARTS	
A WORKING PRINCIPLE.....	p. 3	O VEGA PUMP 23:1 - RIF. 9100 COMPLETE	
B TECHNICAL DATA.....	p. 4	PNEUMATIC MOTOR.....	p.26
C DESCRIPTION OF THE EQUIPMENT.....	p. 7	P STAINLESS STEEL SPLIT VEGA PUMP 23:1 -	
D CARRIAGE AND UNPACKING.....	p.10	COMPLETE PUMPING UNIT.....	p.28
E SAFETY INSTRUCTIONS.....	p.10	Q VEGA SPLIT PUMP 23:1 COMPLETE	
F CONNECTIONS.....	p.11	PUMPING UNIT.....	p.30
Connect the suction and recirculation hoses ...	p.11	R VEGA SPLIT PUMP ON TANK 23:1 COMPLETE	
Connect the gun hose.....	p.11	PUMPING UNIT.....	p.32
Washing the new equipment.....	p.12	S VEGA SPLIT PUMP 23:1 ON TANK	
Preparation of the paint.....	p.13	RIF. 91700.....	p.34
G OPERATION.....	p.13	T COMPLETE TROLLEY.....	p.36
Start spraying operations.....	p.13	U AIRLESS VERSION RIF. 96250 AIR	
Adjusting the spraying jet.....	p.14	REGULATION UNIT.....	p.37
H CLEANING AT THE END OF THE WORK.....	p.15	V MISTLESS VERSION RIF. 96262 AIR	
I ROUTINE MAINTENANCE.....	p.16	REGULATION UNIT.....	p.38
Lubricating the gaskets ring nut.....	p.16	W PAINT SUCTION SYSTEM.....	p.39
Cleaning the suction filter.....	p.16	X AT 250 HIGH PRESSURE GUN.....	p.40
Cleaning the product suction filter.....	p.16	Y ACCESSORIES.....	p.42
J REPLACEMENT OF THE PUMPING		Z VERSIONS.....	p.44
UNIT GASKETS.....	p.17	AA ATEX CERTIFICATION.....	p.47
K CLEANING AND REPAIRING THE		AB TECHNICAL FEATURES.....	p.47
SUCTION VALVE.....	p.19	AC MARKING.....	p.48
L MANUAL SERVICING OF THE		AD SAFETY INSTRUCTIONS.....	p.48
PNEUMATIC MOTOR.....	p.19	AE EXAMPLE OF INSTALLATION.....	p.49
M DISASSEMBLING THE MOTOR.....	p.20	AF DECLARATION OF CONFORMITY.....	p.49

WARNINGS

The table below provides the meaning of the symbols used in this manual in relation to using, grounding, operating, maintaining and repairing of this equipment.

	<p>Read this operator's manual carefully before using the equipment. An improper use of this machine can cause injuries to people or things. Do not use this machine when under the influence of drugs or alcohol. Never modify the equipment. Use products and thinners compatible with the various parts of the equipment and read the manufacturer's warnings carefully. Always refer to the equipment technical data reported in the Manual. Daily check the equipment for worn parts. If any worn parts are found, replace them using ONLY original spare parts. Keep children and animals away from work area. Comply with all safety standards.</p>
	<p>It indicates a risk for accident or serious damage to equipment if this warning is not followed.</p>
	<p>FIRE AND EXPLOSION DANGER Flammable fumes, such as thinners or painting fumes could ignite or explode. In order to prevent fire or explosion risks:</p> <ul style="list-style-type: none"> - Use the equipment ONLY in a well ventilated area. Keep the working area free from scrap materials. - Remove all ignition sources such as pilot lights, cigarettes, portable electric lamps and plastic drop cloths (potential static span) - Ground the equipment and all conductive items located in the work area. - Use only conductive airless tubes, duly grounded. - Never use trichloroethane, methylene chloride, any halogenated hydrocarbon thinners or fluids containing such thinners with aluminium equipment under pressure. This use could cause a dangerous chemical reaction with explosion risk. - Do not connect or switch lights on or off if the air contains flammable fumes. <p>In case of electrical shocks, immediately stop the operation being carried out on the equipment. Keep a fire extinguisher near the working area.</p>
	<p>It indicates the risk of finger injury or crushing due to movable parts in the equipment. Keep far from movable parts. Do not use the equipment without the suitable protections. Before any inspection or maintenance of the equipment, carry out the decompression procedure explained in this manual preventing any risk of the equipment starting unexpectedly.</p>
	<p>They report the risk of chemical reaction or explosion. There is a risk of injury or serious damage related to contact with the jet from the spray gun. If this should occur, IMMEDIATELY contact a doctor, indicating the type of product injected. Do not spray before placing the guard over the nozzle and the trigger on the spray gun. Do not put your fingers in the spray gun nozzle. Once work has been completed, before carrying out any maintenance, complete the decompression procedure explained in this manual.</p>
	<p>It indicates important warnings and suggestions about disposal and recycling of the product in accordance with the environmental regulations.</p>
	<p>It indicates the presence of a clamp with grounding cable. Use ONLY 3-wire extension cords and grounded electrical plugs. Before starting work, make sure that the electrical system is grounded and complying with safety standards. The high pressure product spraying out of the gun or from any lacks could cause body injury. To prevent any fire or injury risk:</p> <ul style="list-style-type: none"> - Use the safety block on the gun trigger when you are not spraying. - Do not put hands or fingers on the gun nozzle. Never try to stop any lack with your hands or body. - Do not direct the gun towards yourself or anyone else. - Never spray without the suitable nozzle protection. - Decompress the system at the end of the spraying process and before any maintenance operation. - Do not use any components having an operating pressure lower than the system max pressure. - Do not let the children use the equipment. - Pay attention to the possible recoil when you trig the gun. <p>Should the high pressure fluid penetrate through the skin, the wound could appear similiar to a "simple cut" even if the damage is more serious. Immediately contact a doctor to medically treat the wound part.</p>
	<p>They indicate the obligation to wear suitable clothing as gloves, goggles and face shield. Wear clothing that complies with the safety standards in force in the country in which the equipment is used. Do not wear bracelets, earrings, rings, chains, or anything else that may hinder the operator's work. Do not wear clothing with wide sleeves, scarves, ties, or any other piece of clothing that could get tangled up in moving parts of the equipment during the work, inspection, or maintenance cycles.</p>

A WORKING PRINCIPLE

VEGA 23:1 pump is a pneumatic pump for high pressure painting without the use of compressed air (AIRLESS). The stainless steel version is particularly suitable for use with water-based paints. The pump is essentially composed of an air motor and a structure known as "Product Pumping Unit", or simply the "Pumping Unit". In the pneumatic motor, the compressed air causes the vertical reciprocating movement of the motor piston; this movement is transmitted through a connecting rod to the product pumping piston. This allows the pump to suck the product and to feed it towards the outlet.

The ratio 23:1 means that the outlet pressure of the product is 23

times higher than the pump feed air pressure.

The unit comes complete with a transportation trolley, a high-pressure product filter, an air supply regulator for the pump, a product suction tube (complete with filter) and a recirculation tube. Our spray guns are tested and controlled in our factory and are delivered to the customer in perfect working conditions.

For this reason, in order not to alter the characteristics of these units, it is advisable to carefully read these instructions and to follow them accordingly.

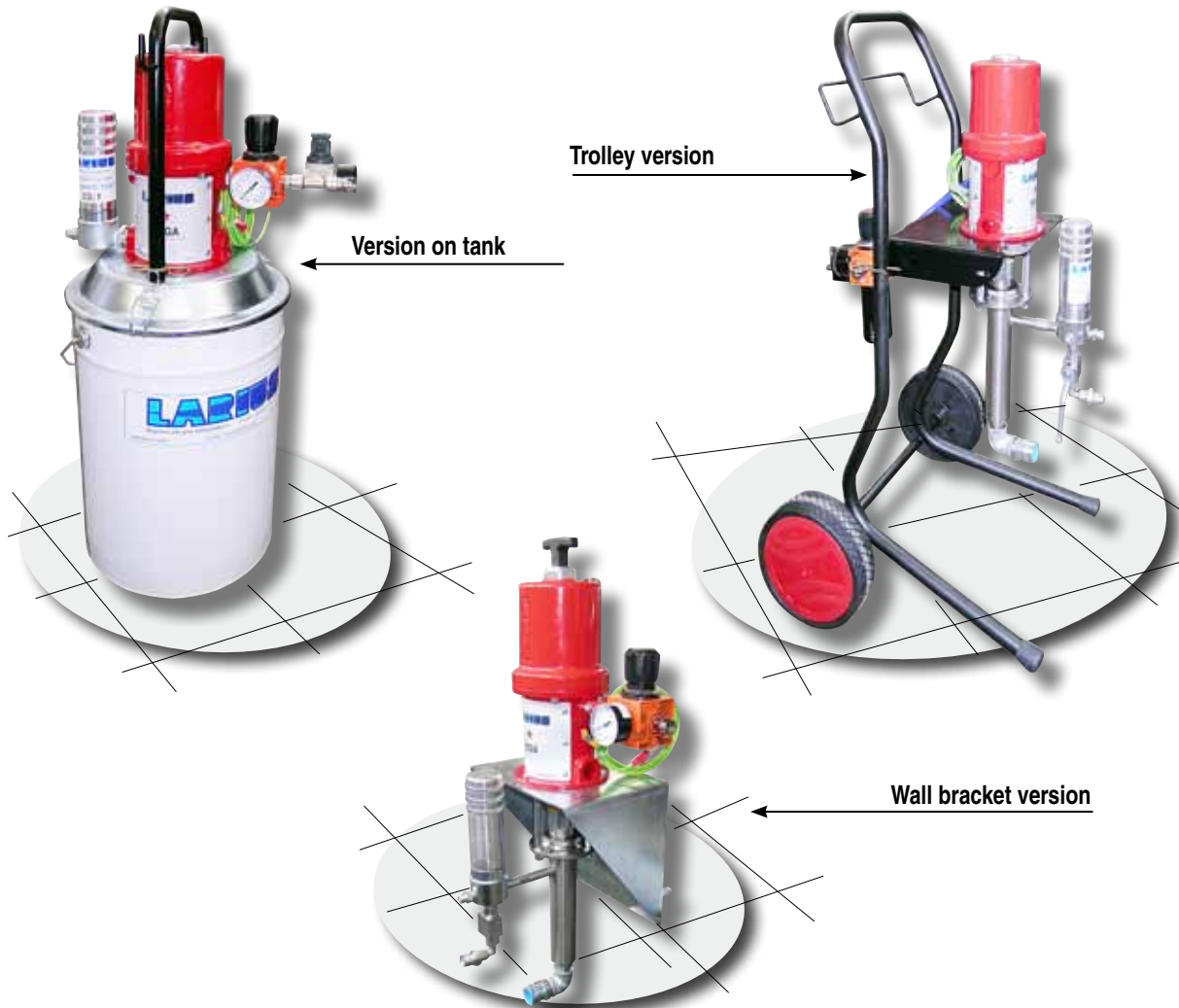

<i>Fields of application</i>	<i>Main application products</i>	
Wood	Paints for wood in general	Degreasers
Carpentry	Very well ground enamels and rust preventers	Detergents
Handcraft	Primers	Oils
Small and medium industry for limited productions	Polyurethan paints	etc...
	Lakes	

B TECHNICAL DATA

		VEGA 23:1
MAXIMUM RATE		2,6l/min (0.7 gpm)
PUMP FEEDING AIR PRESSURE		3-8 bar (40-120 psi)
AIR CONSUMPTION	AT 3 BAR	180 l/min (6.5 cfm at 40 psi)
	AT 5 BAR	380 l/min (13.5 cfm at 70 psi)
	AT 7 BAR	550 l/min (19.5 cfm at 100 psi)
AIR INLET		3/8" GAS (F)
PRODUCT INPUT		3/4" GAS (M)
PRODUCT OUTPUT		3/8" GAS C (F)
TOTAL LENGHT		710 mm
PUMPING UNIT LENGHT		410 mm
WEIGHT		16 Kg
GASKETS		UPPER.: teflon LOWER.: teflon
OVERALL DIMENSIONS		
Trolley version	A HEIGHT	930 mm
	B WIDTH	450 mm
	C DEPTH	450 mm
OVERALL DIMENSIONS version on tank		
	D HEIGHT	780 mm
	E DIAMETER	340 mm
OVERALL DIMENSIONS wall bracket version		
	F HEIGHT	800 mm
	G WIDTH	250 mm
	H DEPTH	290 mm
SOUND PRESSURE LEVEL		<80 dB (A)

Note. The pump is supplied with bayonet coupling.

Parts of the pumpnt in contact with the product

Pumping group: galvanized steel and aluminium or stainless steel (according to versions)
 Sealing balls: stainless steel AISI 420B
 Gaskets: Teflon

Other parts of the pump

Motor body and motor piston: aluminium
 Pneumatic motor piston rod: stainless steel
 Trolley frame: painted metal sheet

These notes shall be kept in consideration in case you need to evaluate the compatibility of a product to be used or when you need to dispose one or more components of the pump, in order to schedule a suitable recycling of the single component according to environment standards.



The pump can operate in continuous mode when the rate is limited to the white area. Outside this area, the speed shall be intermittent.

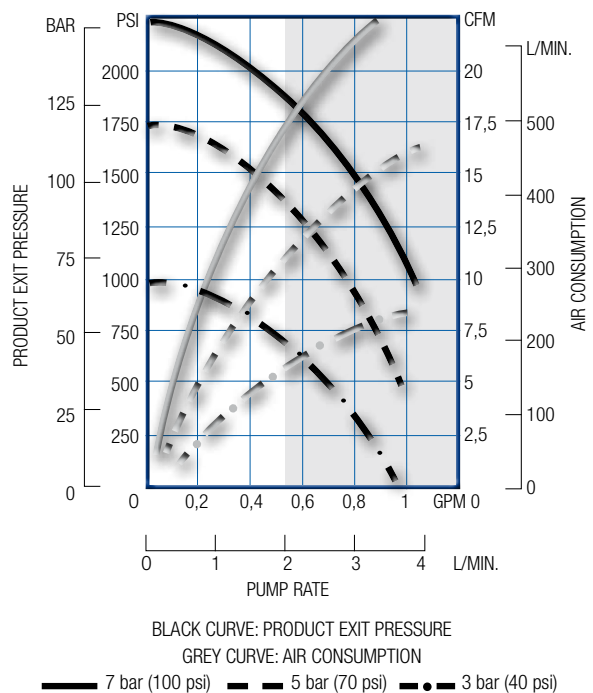

TROLLEY
Version

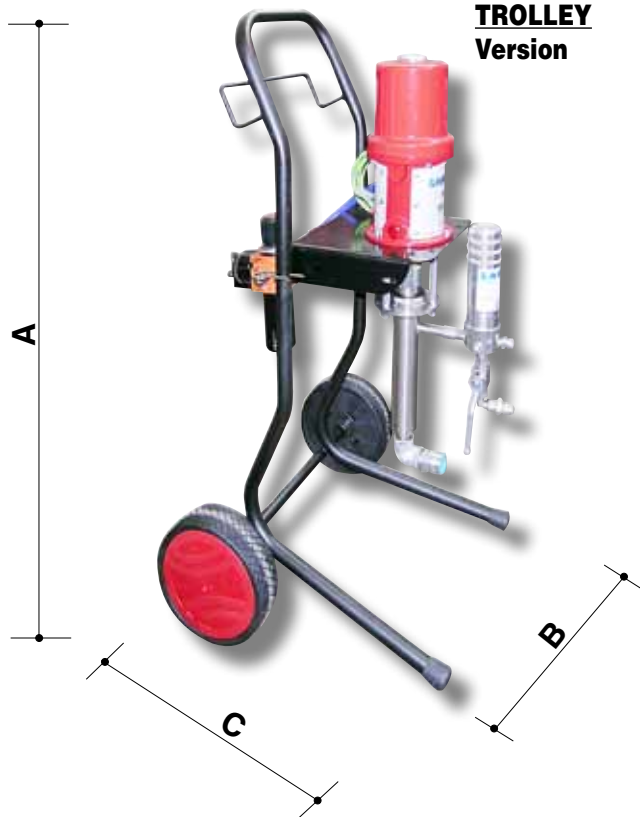

WALL BRACKET
Version

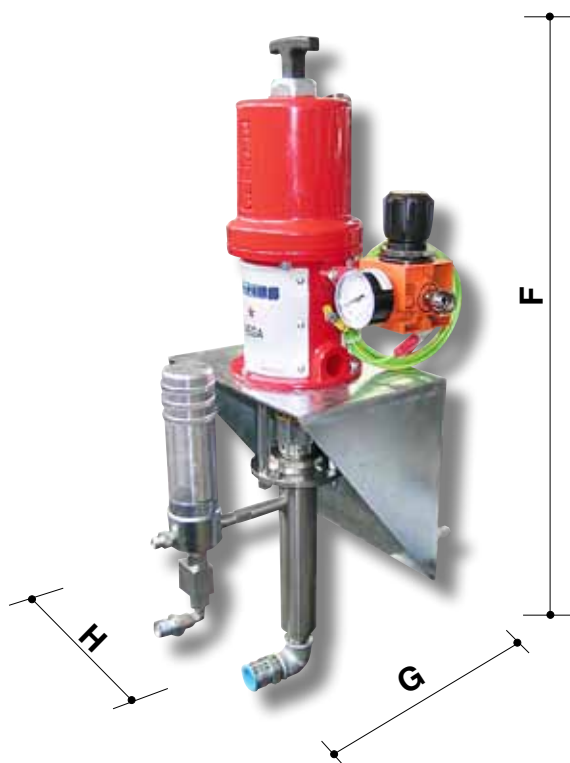

ON TANK
Version



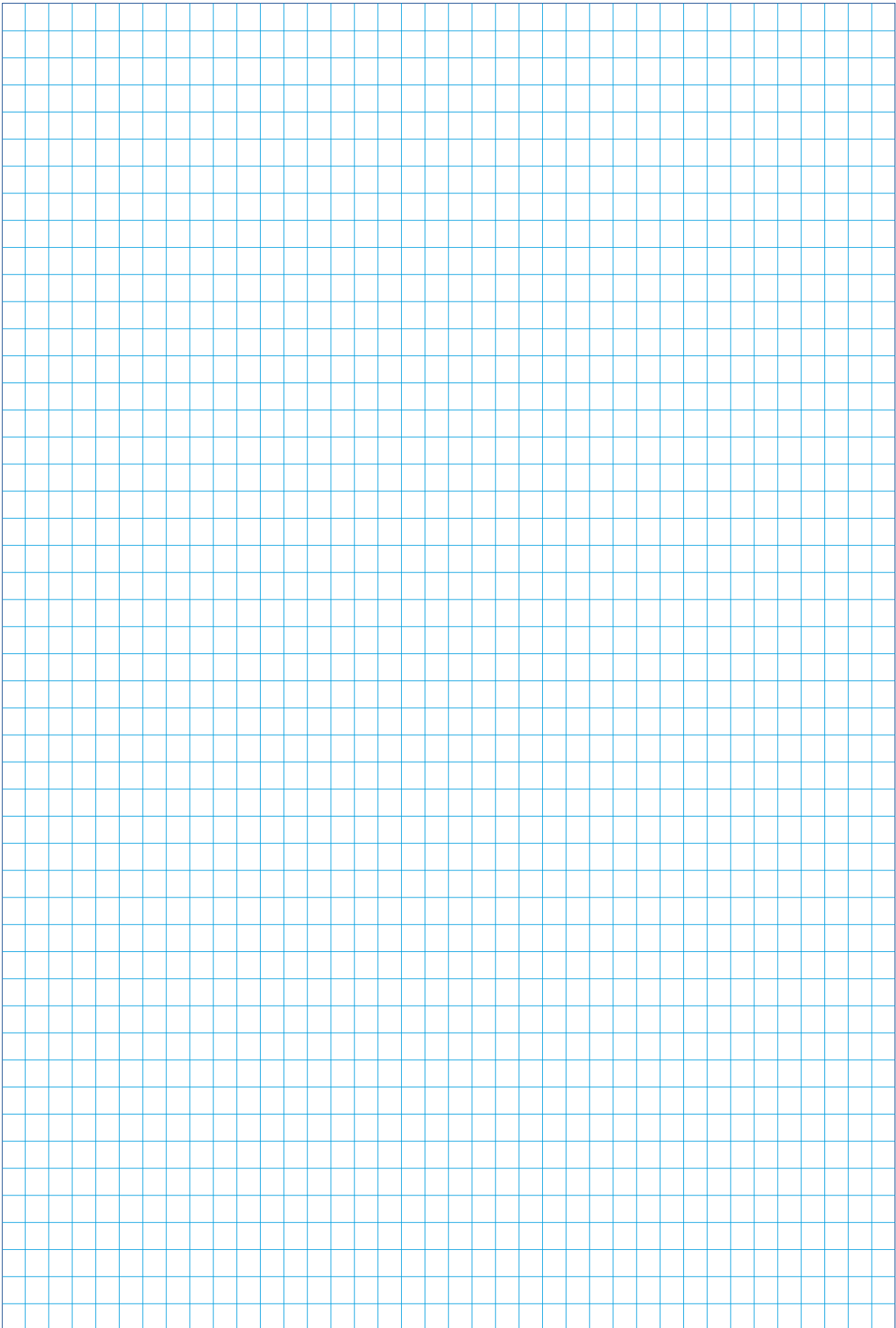

C DESCRIPTION OF THE EQUIPMENT

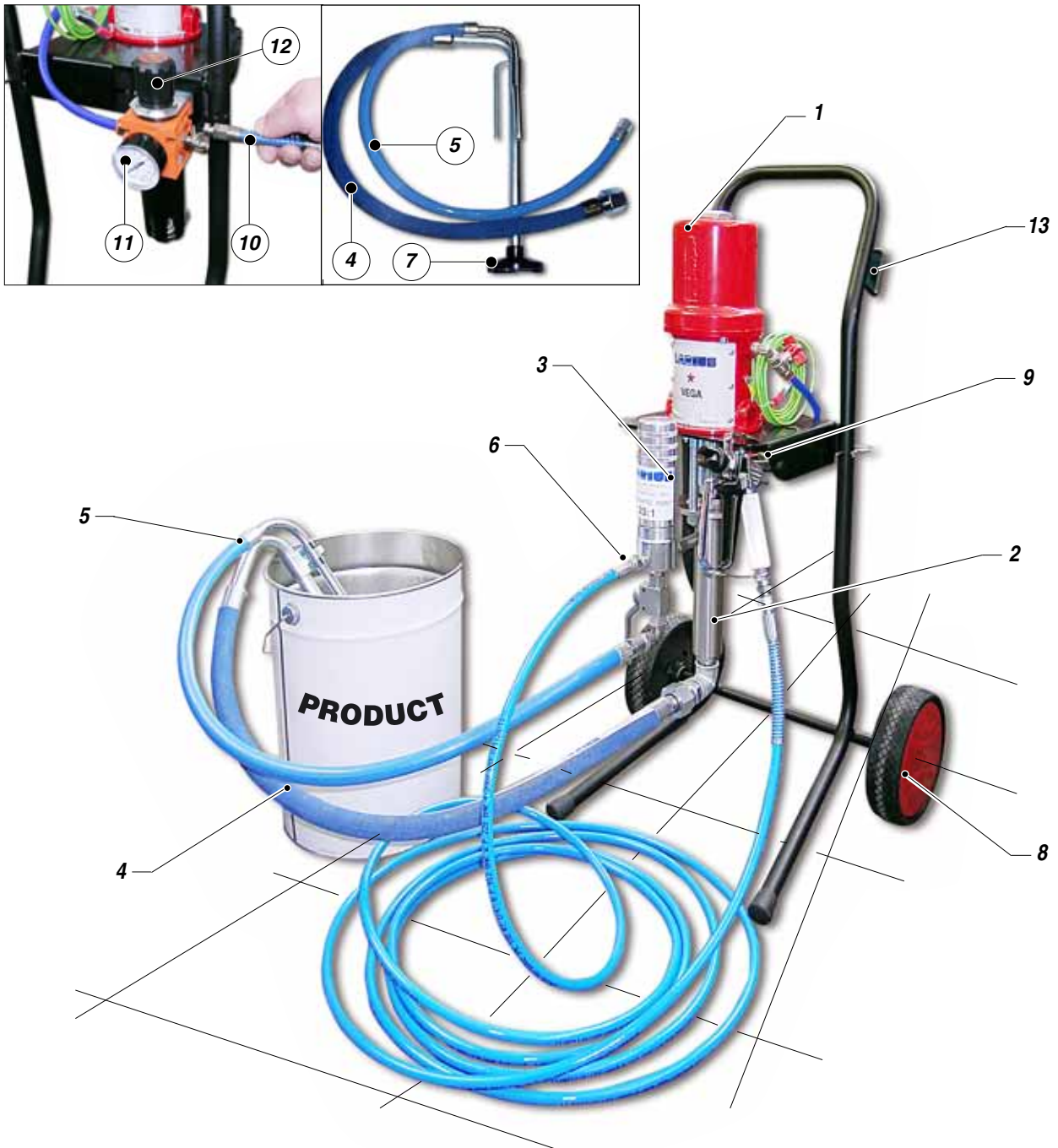

POS.	Description
1	Motor unit
2	Pumping unit
3	Filter unit
4	Suction hose
5	Recirculation tube
6	High pressure tube
7	Product suction filter

POS.	Description
8	Wheels
9	Manual gun
10	Compressed air inlet
11	Pump feeding air pressure gauge
12	Pump feeding air pressure regulator
13	Equipment transport trolley

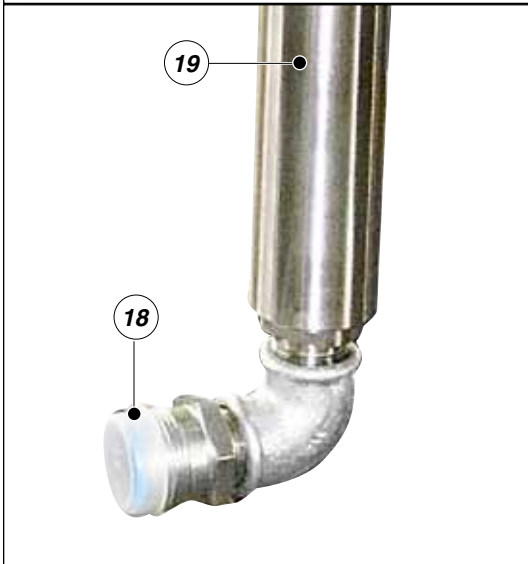
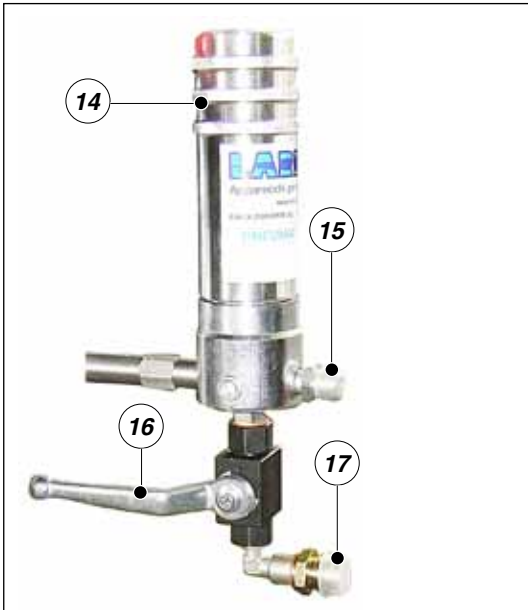

POS.	Description
14	Product exit high pressure filter
15	Product exit fitting
16	Recirculation tap
17	Recirculation tube fitting

POS.	Description
18	Suction hose fitting
19	Product pumping unit
20	Flexible hose air-product
21	AT250 Gun

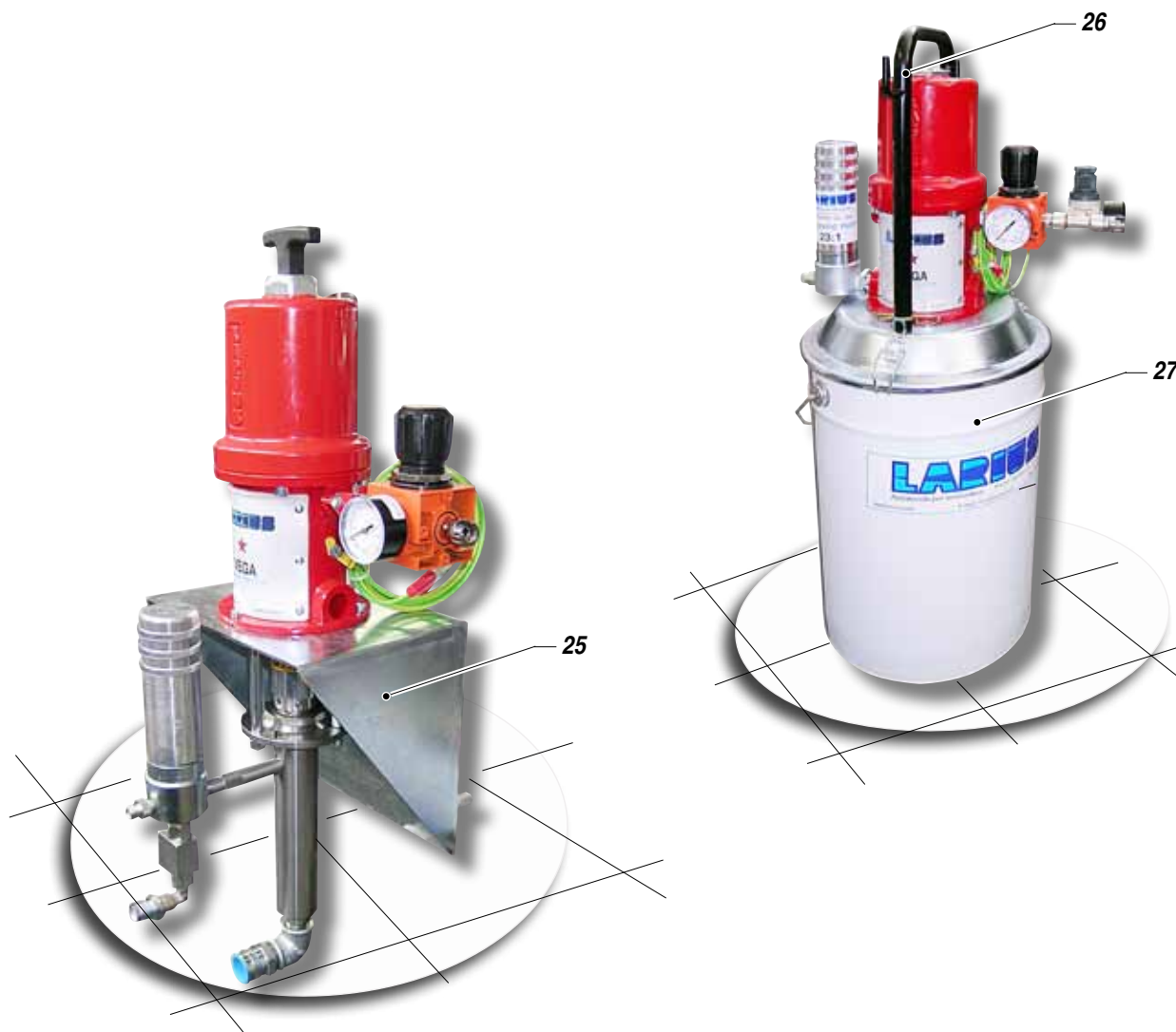

POS.	Description
22	Pump air feeding opening-closing valve
23	Pump pneumatic motor
24	Grounding cable

POS.	Description
25	Wall bracket
26	Lifting handle
27	Container

D CARRIAGE AND UNPACKING

- Strictly respect the orientation of the package indicated externally by labels or symbols.
- Before installing the equipment, prepare an environment suitable in terms of space, proper lighting, clean and smooth floor.



All unloading and handling operations of the equipment are at User's care who should pay the utmost attention in order to avoid any damage to people or things.

The unloading operations shall be carried out by skilled and trained personnel (*truck, crane operators, etc.*) with suitable hoisting means able to bear the weight of the package and to meet all safety standards.

The personnel must be equipped with suitable protective devices.

- The manufacturer declines any liability relevant to the unload and carriage of the equipment to the workplace.
- Check the integrity of the package upon receipt. Remove the equipment from the packaging and check that no damage has occurred during transport. Should any damaged components be found, promptly contact LARIUS and the shipping agent. The maximum deadline to notify the damage is 8 days from the date of equipment receipt. The communication must be made by registered mail with acknowledgement addressed to LARIUS and to the carrier.



The disposal of packaging materials, at user's care, shall be performed in compliance with applicable regulations in force in the country where the equipment is installed.



It is however good practise to dispose the packaging materials in the most environment-friendly way.

E SAFETY INSTRUCTIONS

- THE EMPLOYER SHALL PROVIDE TO DULY TRAIN THE PERSONNEL REGARDING THE RISKS OF ACCIDENTS, THE SAFETY DEVICES AND THE GENERAL ACCIDENT PREVENTION GUIDELINES PROVIDED BY THE INTERNATIONAL DIRECTIVES AND BY THE LAW IN FORCE IN THE COUNTRY WHERE THE UNIT IS INSTALLED, IN ADDITION TO THE STANDARDS RELEVANT TO ENVIRONMENTAL POLLUTION.
- PERSONNEL STAFF SHALL CAREFULLY RESPECT THE ACCIDENT PREVENTION STANDARDS IN FORCE IN THE COUNTRY WHERE THE UNIT IS INSTALLED, IN ADDITION TO THE RULES RELEVANT TO ENVIRONMENTAL POLLUTION.



Carefully read the following instructions before using the equipment.
Keep these instructions with care.

Tampering or unauthorized replacement of one or more parts composing the equipment, the use of accessories, tools, consumables other than those recommended by the manufacturer, might represent a risk of injury and raise the manufacturer from any liability and penalty.

- KEEP THE WORKING AREA IN GOOD ORDER. FAILURE IN RESPECTING THIS MAY CAUSE RISK OF ACCIDENTS.
- ALWAYS KEEP A GOOD BALANCE AVOIDING UNSAFE POSITIONS.
- BEFORE STARTING OPERATION, CAREFULLY CHECK THAT THERE ARE NO DAMAGED COMPONENTS AND THAT THE EQUIPMENT IS ABLE TO OPERATE CORRECTLY.
- ALWAYS FOLLOW THE SAFETY INSTRUCTIONS AND REGULATIONS IN FORCE.
- KEEP UNAUTHORIZED PERSONNEL AWAY FROM THE WORKING AREA.
- **NEVER** EXCEED THE MAXIMUM OPERATING PRESSURE
- **NEVER** DIRECT THE GUN TOWARDS YOURSELF OR ANYONE ELSE. GETTING IN TOUCH WITH THE JET MIGHT CAUSE SERIOUS WOUNDS. IN CASE OF WOUNDS DERIVED BY THE GUN JET, IMMEDIATELY PROVIDE FOR MEDICAL ASSISTANCE SPECIFYING THE PRODUCT YOU WERE USING. NEVER UNDERESTIMATE THE WOUND CAUSED BY THE INJECTION OF A FLUID.
- ALWAYS DISCONNECT THE POWER SUPPLY AND DISCHARGE THE PRESSURE IN THE CIRCUIT BEFORE PERFORMING ANY CONTROL OR REPLACEMENT OF EQUIPMENT COMPONENTS.
- NEVER MODIFY ANY EQUIPMENT COMPONENT. PERIODICALLY CHECK THE COMPONENTS OF THE SYSTEM. REPLACE DAMAGED OR WORN COMPONENTS, IF ANY.
- CHECK AND TIGHTEN ALL FITTINGS BETWEEN THE PUMP, THE FLEXIBLE HOSE AND THE GUN BEFORE USING THE EQUIPMENT.

- ALWAYS USE THE HOSE PROVIDED IN THE STANDARD KIT. USE OF EQUIPMENT OR ACCESSORIES OTHER THAN THOSE RECOMMENDED IN THIS MANUAL MAY CAUSE ACCIDENTS.
- THE FLUID CONTAINED IN THE FLEXIBLE HOSE CAN BE VERY DANGEROUS. HANDLE THE HOSE WITH CARE. DO NOT PULL THE HOSE TO MOVE THE EQUIPMENT. NEVER USE A DAMAGED OR REPAIRED HOSE.
- MAKE SURE YOU KNOW HOW TO STOP THE EQUIPMENT WHEN NEEDED. IT IS ALSO RECOMMENDED TO TRAIN THE USERS ON THE SAFE AND CORRECT USE OF THE EQUIPMENT BEFORE STARTING OPERATIONS.
- KEEP UNAUTHORIZED PERSONNEL FAR FROM THE EQUIPMENT, ESPECIALLY IF THE PRODUCT TO BE USED IS TOXIC .
- IF NECESSARY, USE WARNING SIGNALS TO KEEP ANY UNAUTHORIZED PERSON AT A SAFE DISTANCE.
- MAKE SURE THAT THERE IS SOMEONE HEARING YOU IN THE UNLIKELY EVENT OF AN ACCIDENT.

 The high speed of the product flowing in the flexible hose may cause statical electricity showing short sparks. It is recommended to provide a suitable grounding for the equipment. The pump is connected to the ground cable of the electric supply. The gun is grounded by means of the high pressure flexible hose. Each conductive parts near the workplace shall be duly grounded .

- NEVER SPRAY FLAMMABLE PRODUCTS OR THINNERS IN CLOSED ROOMS.
- NEVER USE THE EQUIPMENT IN PRESENCE OF POTENTIALLY EXPLOSIVE GASES.

 Always check the compatibility of the product with the materials composing the equipment (pump, gun, hose and accessories) with which it can come into contact. Do not use paint or thinners containing halogenated hydrocarbon (such as methylene chloride). These products, when in contact with equipment aluminum parts, can cause dangerous chemical reactions thus representing a risk of explosion.

 IF THE PRODUCT TO BE USED IS TOXIC AVOID INHALATION AND CONTACT, BY USING PROTECTIVE GLOVES, GOGGLES AND SUITABLE FACE SHIELDS.

 ADOPT SUITABLE HEARING PROTECTION MEASURES WHEN WORKING NEAR THE EQUIPMENT.

F CONNECTIONS

CONNECT THE SUCTION AND RECIRCULATION HOSES

- Connect the suction (F1) and the recirculation hoses (F2) to the pumping unit (F3) and to the filter (F4) as indicated in the picture.

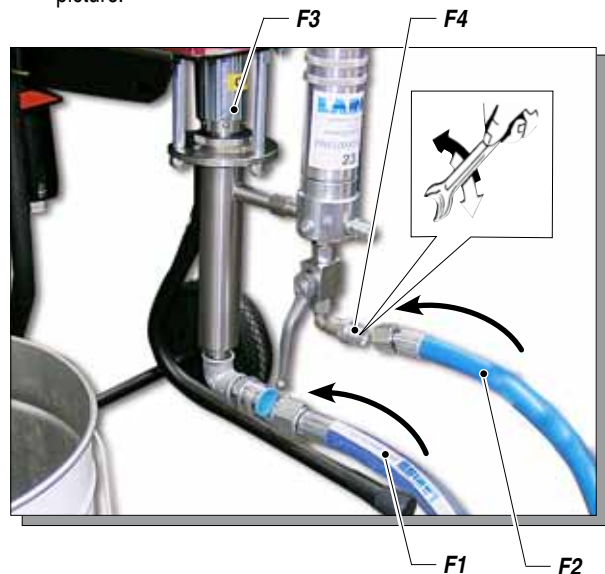

CONNECT THE GUN HOSE

- Connect the product feeding hose (F5) to the filter unit (F6).

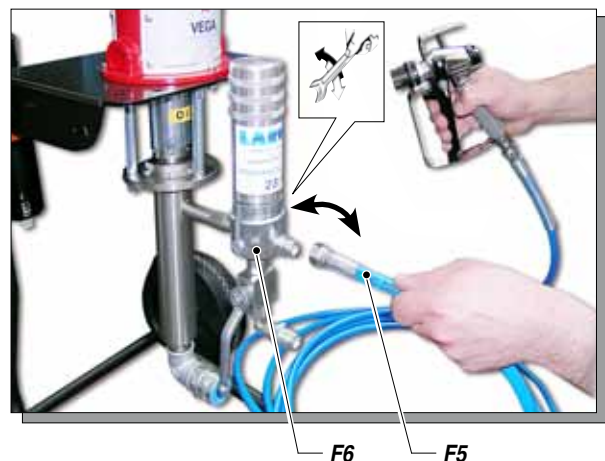

CONNECT THE FEEDING AIR HOSE

- Connect the adjustment group (F7) to the compressed air fitting (F8).



- Set the pump feeding pressure at about 3 bar and open the air valve.

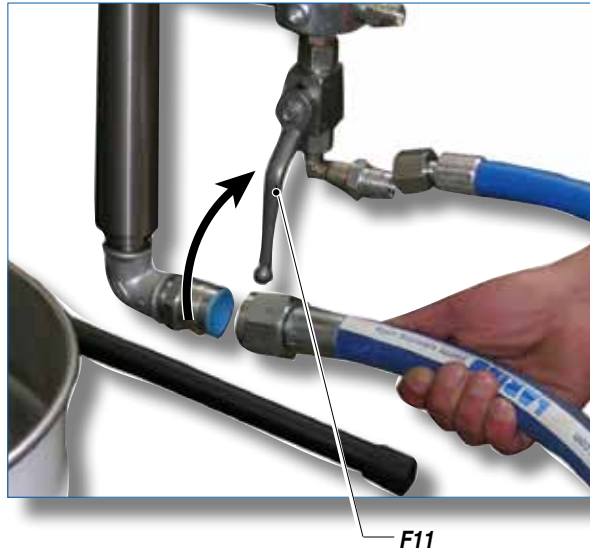

NEVER use thread adhesive products on the fittings. We recommend the use of the hose included in the standard kit.
NEVER use a damaged or repaired flexible hose.

WASHING THE NEW EQUIPMENT

- Our equipment has been tested in our factory with a light mineral oil which is being left inside the unit for protection. Before sucking the product, it is necessary to duly wash with a thinner.
- Plunge the suction hose (F9) in the container of the washing thinner.
- Plunge the recirculation hose (F10) in a collector (a metal container is recommended).
- Open the recirculation tap (F11).

- The pump will start and will discharge the oil for the recirculation hose. Close the recirculation tap as soon as the clean thinner begins to flow.
- Take the suction hose out of the product container.
- At this point place the gun against the collector (F12) and press the trigger in order to discharge the residual oil. Release the trigger as soon as the clean thinner begins to flow.
- Direct the gun against the thinner container and press the trigger in order to recover the clean thinner left inside the pump.
- As soon as the pump begins to work in an accelerated way ("vacuum") close the air valve.

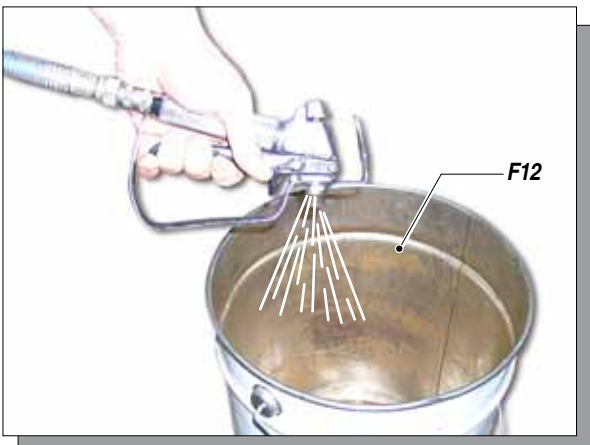
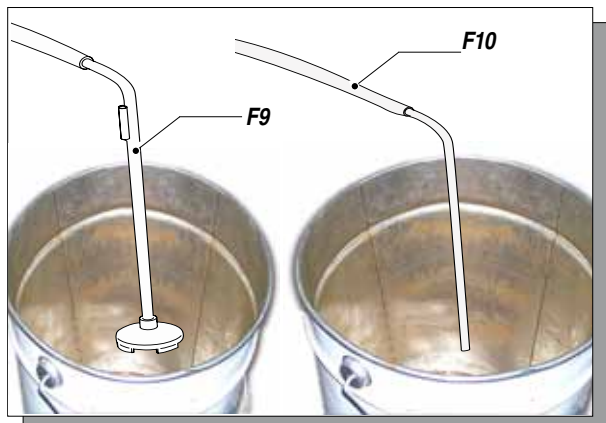

Never operate the pump without the product, in order to prevent the gaskets to be damaged.

Never spray cleaning liquids in close rooms. It is also recommended to place yourself far from the pump in order to avoid the contact with the cleaning liquids vapours.

- At this point the unit is ready. Should water paints be used, it is advisable to wash with soap water and then with clean water, besides the washing with cleaning liquid.

PREPARATION OF THE PAINT

- Make sure that the product is suitable to be sprayed.
- Duly mix and filter the product before use. We recommend the use of LARIUS METEX filters with fine-mesh (Rif. 214) or large mesh (Rif. 215).



Make sure that the product is suitable to be used with the materials employed for the unit manufacturing. For this purpose, refer to the product supplier.

- Rotate clockwise the pressure adjustment knob (F10) so that the pump starts to work.

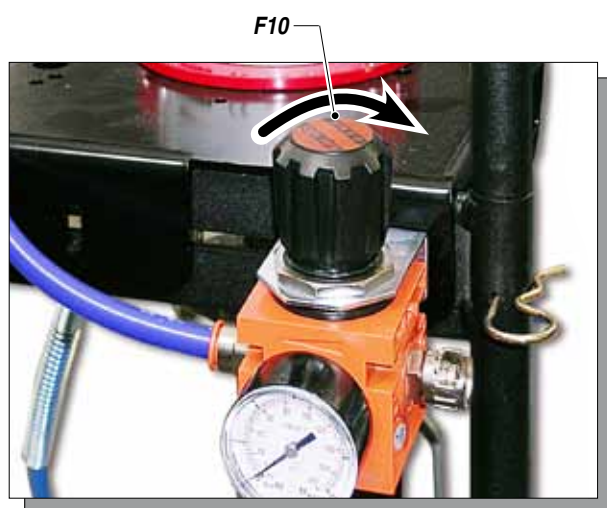

- When the product has been duly mixed, the product will flow from the recirculation hose. (F2)
If the product does not flow, this means it is too thick and it is necessary to dilute it again until a correct flow is achieved. Let the product flow for a short time. At this point, the machine is ready to work.

G OPERATION

PRODUCT PREPARATION

- Make sure that the product and the thinner are suitable to be sprayed. Make sure that the thinner is suitable to be used with the product to be sprayed. Make sure that the product has been duly filtered and mixed.

NOZZLE AND FILTERS

- The nozzle and the filter shall be suitable for the gun, according to the product to be sprayed and to the operation to be carried out (refer to the assembly tables and instructions).

NOZZLE SIZE ACCORDING TO THE PRODUCT

NOZZLE Ø	PRODUCT
mm 0,18 ÷ 0,28 inch 0,007" ÷ 0,011"	Paints and products without pigments and charges. Very fine and with low viscosity paints and lakes, enamels, primers, polyesters, oils, degreasers and detergents, polyurethan paints.
mm 0,33 ÷ 0,62 inch 0,013" ÷ 0,025"	Normal lakes or having higher viscosity, fillers, products with a coarse grinding, rust preventers, vinyl products for coverings, etc.
mm 0,68 ÷ 0,94 inch 0,027" ÷ 0,037"	Same products with a high yield, eposidic resins, dispersion for the building industry, applications with high thickness.

- This table is for indication only. The adaptability of a certain product to a determined nozzle changes according to different aspects. If previous experiences are lacking, a practical test is always necessary. A nozzle, which has been duly chosen, will give as result a neat jet without pulsations and gives a perfect praying of the product.
- An inconstant spray, slightly marked on the sides, might indicate a too low pressure. If the maximum pressure has already been reached, it is then necessary to choose a smaller nozzle. With the exclusion of some products, which can be atomized at high pressures only, it is advisable not to exceed the value of 140-170 Atm (high pressure could cause mist).

- Considering an equal speed of application, a nozzle with a spraying angle of 20° lays down a film having a thickness which is averagely double in respect to the one which can be obtained with the same nozzle with an angle of 60°.
- An excessive diameter of the angle could result in an anomalous pressure drop.
- When ordering a nozzle, choose accurately the reference number on the list of the nozzles.

START SPRAYING OPERATIONS

- Use the equipment only after having completed all the adjustment operations described in the previous paragraph.



Before using the equipment, check all the connection fittings on the various components (pump, flexible hose, gun, etc.)

- Use the provided lubricant (G1) (rif. 16325) in order to make the sliding of the piston easier inside the sealing pack and interpose oil to air.



! Daily check that the ring nut is covered with hydraulic oil (rif. 16325); the oil improves the sliding of the piston and prevent the product, coming out from sealing gaskets, to dry once the equipment is stopped.

- Fix the spraying nozzle on the gun, choosing the suitable nozzle according to the characteristics of the product to be used and the kind of operation to be performed.

! Plunge the suction hose (G1) and the recirculation hose (G2) in the product container (G3).



- Open the recirculation tap.
- When the air tap (G4) is closed, make the air flow from the compressed air supply. Check on the pressure gauge (G5) that the pressure does not exceed 2-3 Atm [adjust it with the knob (G6) of the regulator].



! With an empty pump, a higher pressure might cause a quick and violent movement of the piston, which could be dangerous. Beside this, starting with the max pressure (6-8 bar) the pump will not be able to fill the chamber considering the high speed of the cycle.

- Open the air tap (G4).





- Let the product flow for a few seconds. Then close the recirculation tap. The pump will continue to work until the product will fill the high pressure flexible hose up to the gun, then it will stop.
- Should the cycle speed be too high, decrease the feeding pressure or slightly close the air tap (G4). Set the minimum pressure necessary for the operation.

At the end of the work, stop the pump in the lower position in order to prevent the product to dry on the piston and to damage the gaskets.

ADJUSTING THE SPRAYING JET

- Slowly turn clockwise the pressure adjustment knob until the suitable value able to grant a proper atomization of the product is reached.
- An inconstant spray, slightly marked on the sides, might indicate a too low pressure. On the contrary a too high pressure might cause mist (*overspray*) and product dispersion.
- Do not spray without the contemporaneous advancement of the gun (*right-left*) in order to avoid an anomalous thickness of the paint.
- Always proceed with regular and parallel passages.
- Keep a constant distance (25/30 cm) between the nozzle and the support to be sprayed and keep yourself perpendicular to it.
- Avoid to work with maximum pressure.

 	<p>NEVER direct the gun towards yourself or anyone else.</p> <p>Getting in touch with the jet might cause serious wounds. In case of wounds derived by the gun jet, immediatly provide for medical assistance specifying the product you were using.</p>
--	---

	<p>Recirculation-safety valve: during the operation at the maximum pressure available, when releasing the gun trigger, you can assist to brisk pressure increasings. In this case the recirculation-safety valve automatically opens, discharging part of the product from the recirculation hose. It then closes in oder to set the previous working conditions.</p>
---	--

CLEANING AT THE END OF THE WORK

- Remove the suction (H1) and the recirculation hoses (H2) from the product container (H3) by going on spraying (H4), until the pump is completely empty.

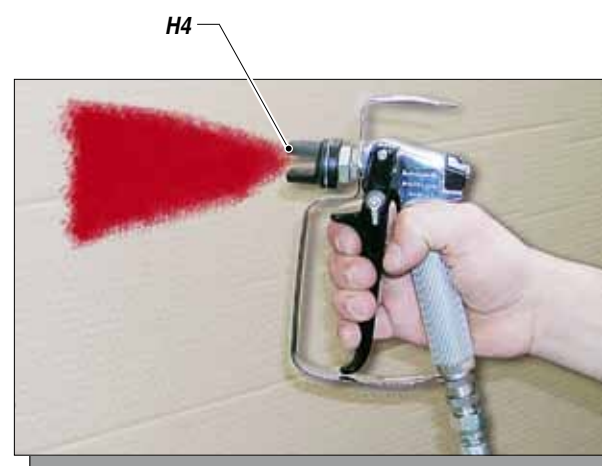
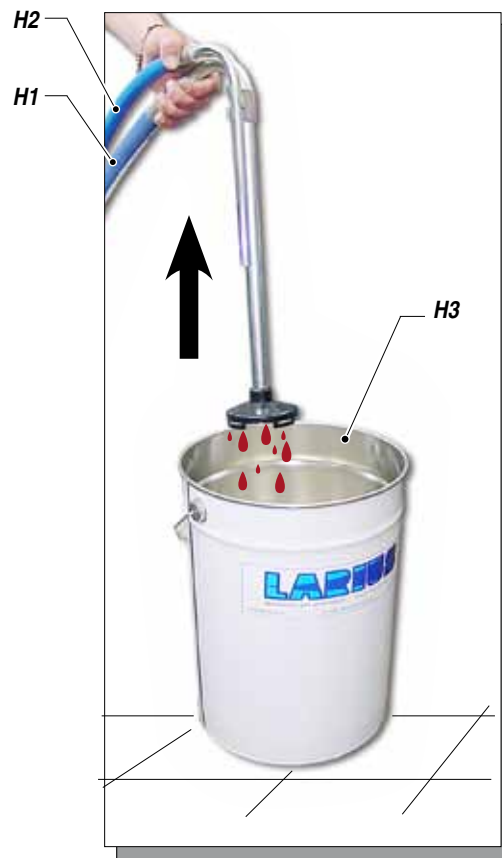

- Plunge the suction (H5) and the recirculation hoses (H6) in the thinner container (H7). Set pressure to the mimimum and by keeping the nozzle below the thinner level in the container, spray until the thinner has been recycled during three or five minutes.

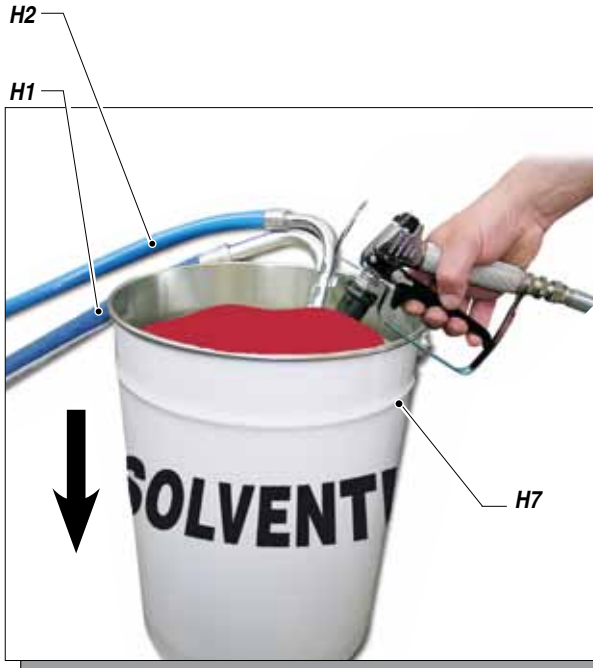

- By going on spraying, lift the suction (H8) and the recirculation hoses (H2), in order to drain out all the thinner. Then stop the pump, by closing the air tap.

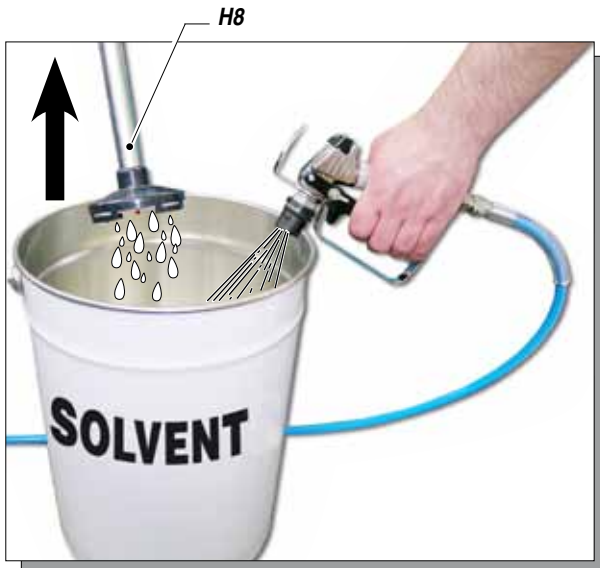

- After washing, in case a long period of downtime is foreseen or if a water-based product has been used, it is advisable to lubricate the inner parts (pumping group), by sucking the hydraulic oil with the pump, without discharging it.

 Before using the equipment, make sure to follow the cleaning procedure.

I ROUTINE MAINTENANCE

 Periodically check the air supply line to the pump. Make sure that the air is always clean and lubricated.

 Before carrying out any control or maintenance operation on the pump, always close the compressed air supply and discharge the pressure in the circuit.

LUBRICATING THE GASKETS RING NUT

- Periodically check (and in any case each time the pump is started after a long period of downtime) that the gaskets ring nut is tight in order to avoid any product leak.
- Weekly check that the gaskets ring nut (I1) is tight. To tighten the gaskets ring nut (I1) use the provided wrench (I2). The ring nut shall be duly tightened so that to prevent any leak but this shall not be excessive in order to avoid the blocking of the pumping piston and the wear of the sealing gaskets. Should the product leak, provide to replace the upper gaskets. This adjustment shall be carried out after having removed the air feeding tube and having discharged the pressure.

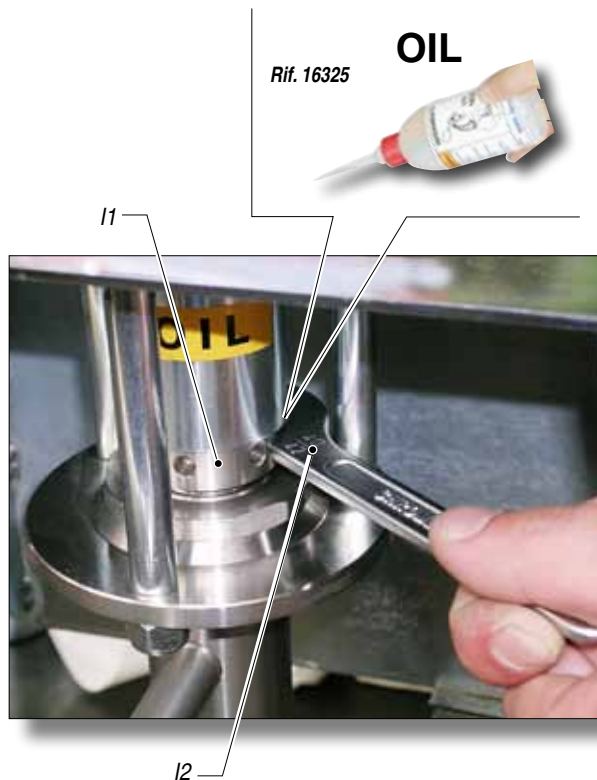



Daily check that the ring nut is covered with hydraulic oil (*rif. 16325*); the oil improves the sliding of the piston and prevent the product, coming out from sealing gaskets, to dry once the equipment is stopped.

CLEANING THE SUCTION FILTER

- Disassemble and clean the product suction filter (I3).

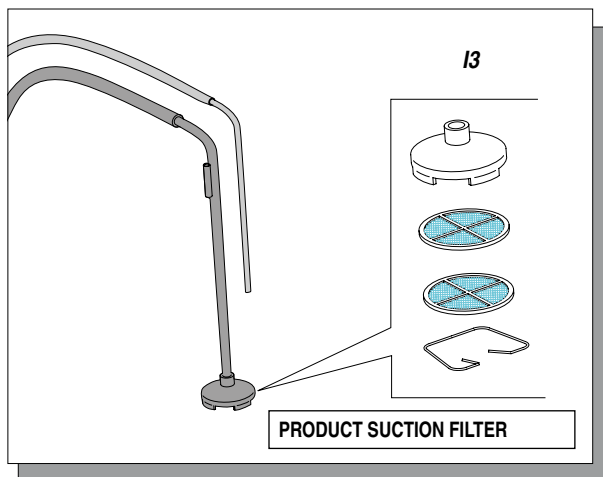

CLEANING THE PRODUCT SUCTION FILTER

- Disassemble and clean the high pressure filter for product output (I4).

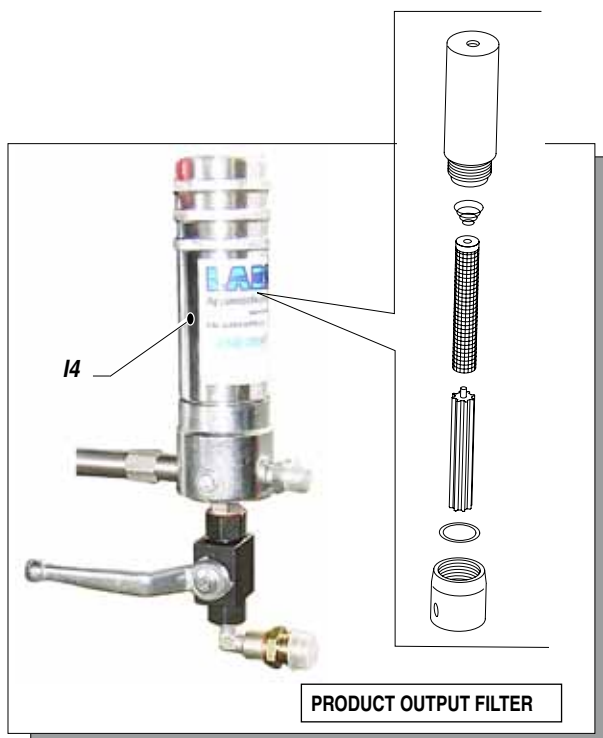

J REPLACEMENT OF THE PUMPING UNIT GASKETS

- Unscrew the filter group (J1) from the pump housing (J2).

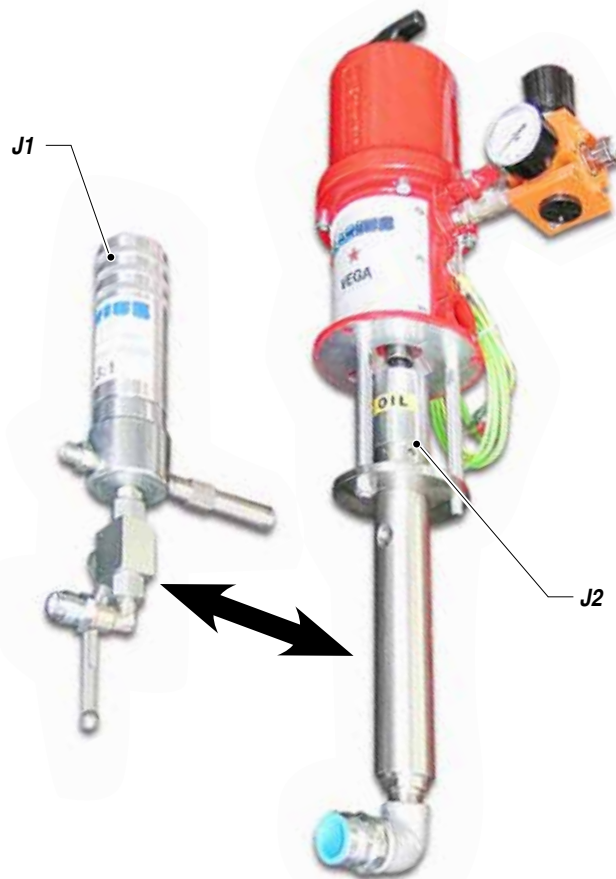

- Unscrew the three self-locking nuts (J3) and remove the pumping unit (J4), by unscrewing it from the motor piston rod.



- Remove the split pin (J6).

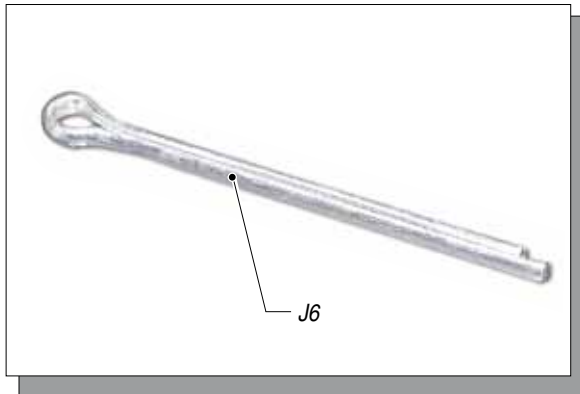

- Unscrew the gaskets ring nut (J7) from the pump housing. Unscrew the group of the suction valve (J8).

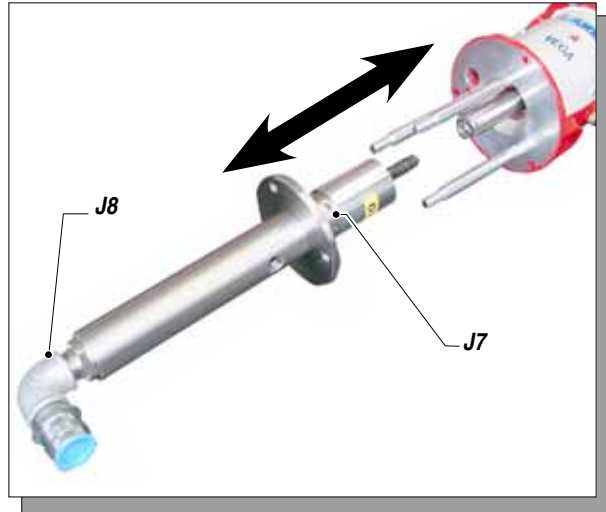

- Remove the piston (J9) from the pump housing and replace the gaskets upper set (J10) or lower set (J11) respecting the assembly order of the same.



When reassembling the seat of the valve (J12) in the piston (J9) the thread shall be covered with threads braking adhesive.

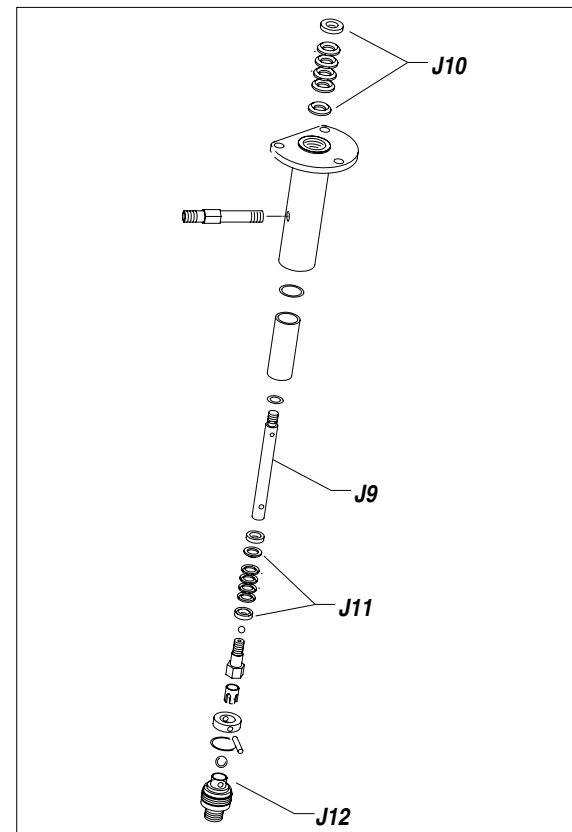

K CLEANING AND REPAIRING THE SUCTION VALVE

- If the suction valve is seized in the housing of the pump, inject oil around the thread and knock slightly around the body of the pump by means of a wooden mallet. Unscrew the valve from the pump body.

Remove the pin (**K1**) holding the ball, as well as the ring stop (**K2**), the O-ring (**K3**), the ball (**K4**). Clean all the parts, inspect them and reassemble all the parts in the same order, by screwing the valve in its seat.

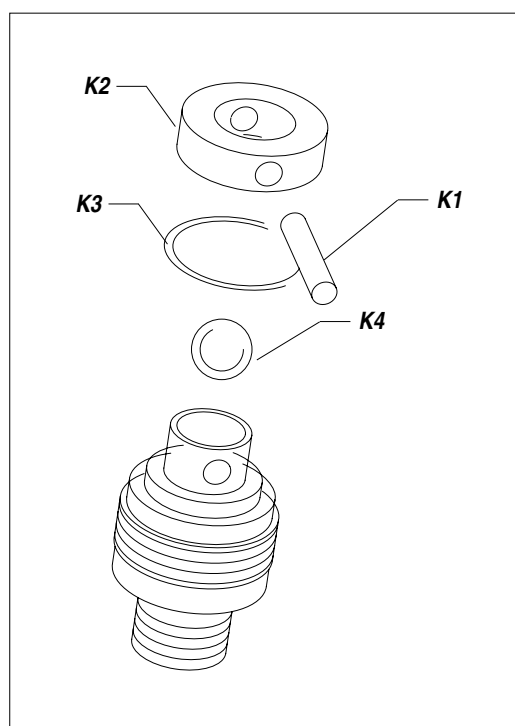

L MANUAL SERVICING OF THE PNEUMATIC MOTOR

- The pump feeding air pressure shall never be higher than the maximum value provided by the technical data sheet. Failure in respecting this value could cause the blocking of the valves of the pneumatic motor in the cycle inversion position.
- In order to restart a blocked motor, close the air feeding valve and release the air pressure in the circuit. This should allow the return of the valves in the correct position.
- Should the motor be blocked, proceed as follows:
 - close the air supply to the pump and discharge the residual pressure in the circuit;

- unscrew the plug (L1) and pull it upwards together with the guide rod (L2), by making thus manually trig the run inversion group.
- screw the plug.

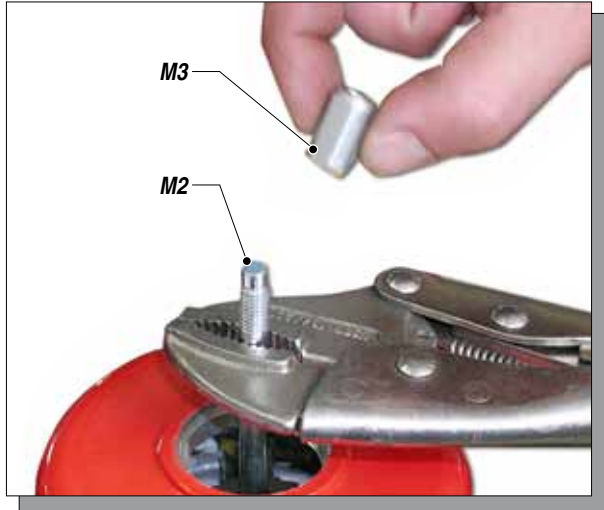
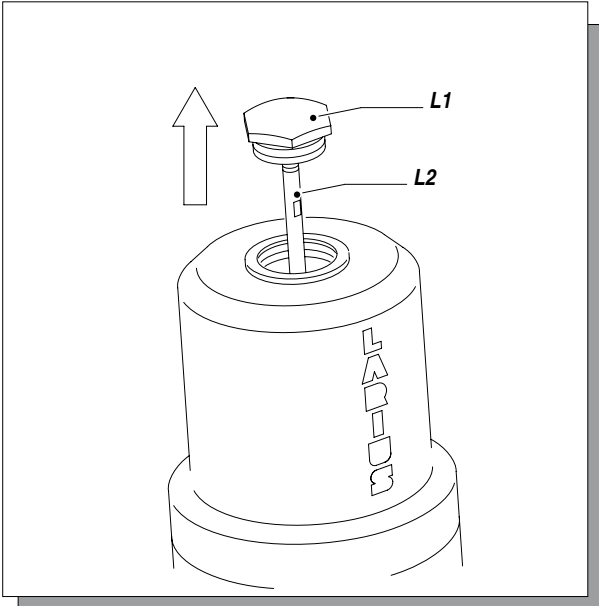

- Remove the screws (M4).



M DISASSEMBLING THE MOTOR

- Place the piston to the upper point of its run and unscrew the plug (M1). Block the guide rod (M2) with clamping pliers and replace the plug (M1) with a M8 nut (M3).



- Take out the cylinder (M5) with the utmost care from the piston, without inclining it in order to avoid damages to the inner walls of the same.

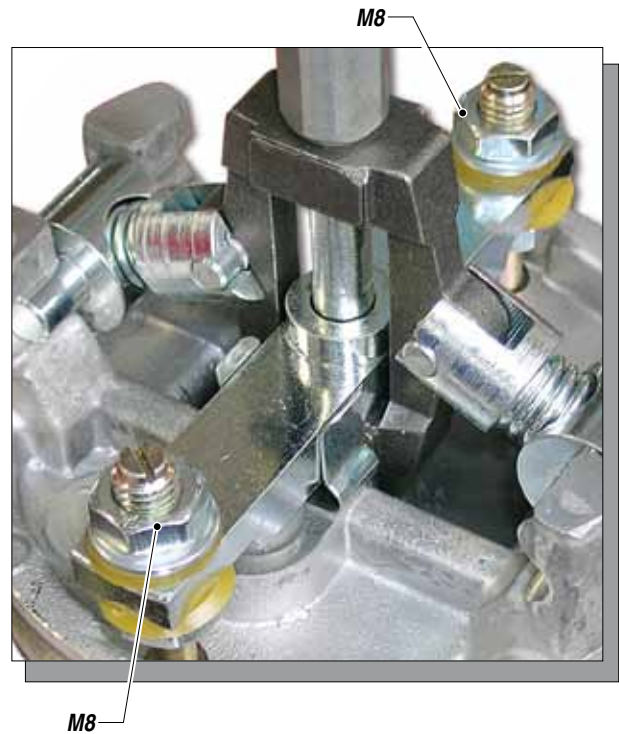

- By keeping the hands far from the cross piece (M6), press on the rocker arm (M7) so that the cross piece (M6) trigs downwards (*drain valves closed*).



- Remove the valve screws (M9) and check the wear condition of the gaskets (M10).

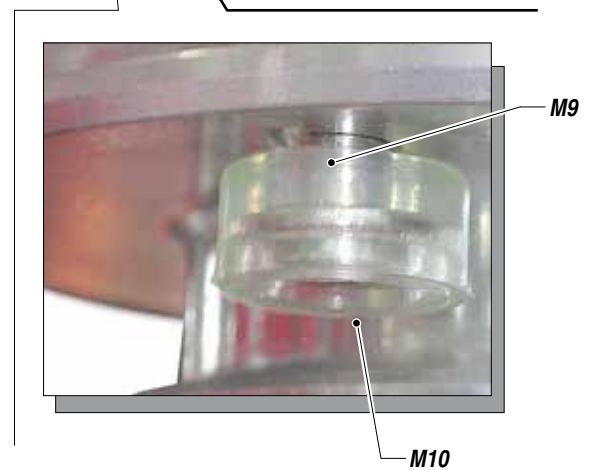
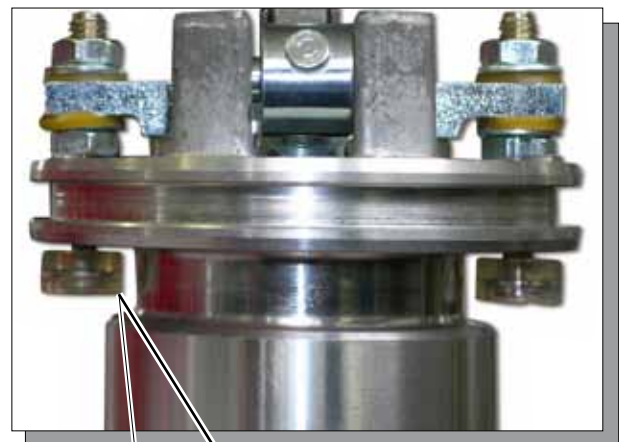

- Unscrew the two counter-nuts (M8) which block the valve screws.

- Block the roller (M11) with the pliers and by pressing on the spring (M12), remove it from its seat. In this way, it will be possible to remove all the run inversion group.

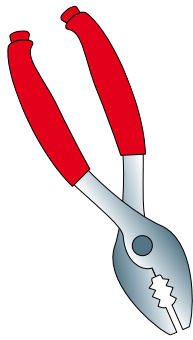

M12

M11

- Check the condition of each piece, in particular of the gaskets (M13) and the O-ring (M14), (M15) and (M16). Control that the inner walls of the cylinder are not scratched. Before reassembling all parts, lubricate them with light and water proof grease.



M13

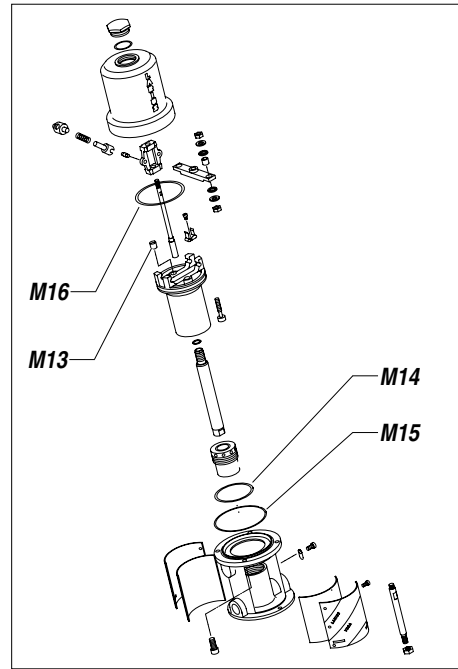

- Adjust then the distance (A) between the gaskets and the surface of the piston. This adjustment shall be done with the cross piece (M7) down and it can be better done by using our special metering device. After having reassembled all parts, before connecting the group to the pump, test it by feeding a small quantity of air (3-4 bar).

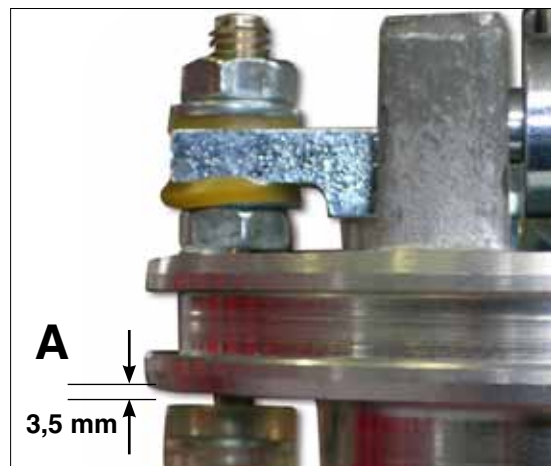

A

3,5 mm

- For a correct reassembly, refer to the pumping group detailed drawing, by following the disassembly instructions in reverse order.



N TROUBLESHOOTING

Faults	Possible cause	Solution
<ul style="list-style-type: none"> The pump does not work 	<ul style="list-style-type: none"> Feeding air is not sufficient. Product outlet line is clogged; Product inlet line is clogged; Pneumatic motor is blocked in the position of cycle inversion; Some components of the pneumatic motor are damaged ; 	<ul style="list-style-type: none"> Check the air supply line. Increase the diameter of the feeding air pipe; Open the recirculation nozzle and check that the pump starts. Unscrew the high pressure filter and clean and/ or replace the filter sieve. Clean and/ or replace the gun filter; Clean the suction filter; Decrease the feeding pressure; Manually service the pneumatic motor; Disassemble the motor and inspect it;
<ul style="list-style-type: none"> The operation of the pump is accelerated and without pressure 	<ul style="list-style-type: none"> The product is lacking; The pump is sucking air; The gaskets of the pumping rod are worn; The suction valve is worn or partially clogged; The suction filter is clogged; The suction filter is too thin; 	<ul style="list-style-type: none"> Add product; Check the flexible suction hose; Replace the lower gaskets; Disassemble the suction valve. Clean and/or replace any worn component. Clean and/or replace the two discs of the suction filter; Remove the fine-mesh filter disc and leave only the large-mesh filter disc.
<ul style="list-style-type: none"> The pump works but it does not stop when the chamber is full (the pumping unit slowly moves up and/or down) 	<ul style="list-style-type: none"> The gaskets of the pumping shaft are worn; The suction valve is worn or partially clogged; The feeding valve is worn or partially clogged; Upper gaskets are worn; 	<ul style="list-style-type: none"> Replace the lower gaskets Disassemble the suction valve and clean and/or replace any worn detail Disassemble the feeding valve and clean and/or replace any worn detail Tighten the gaskets ring nut
<ul style="list-style-type: none"> By pressing the gun trigger, the pressure of the product highly decreases 	<ul style="list-style-type: none"> Gun nozzle is too big or worn Gun filter and the filter sieve for product outlet are too thin 	<ul style="list-style-type: none"> Replace it with a smaller one Replace them with larger-mesh filters



Before performing any inspection or replacement of the pump components, make always sure to close the compressed air supply and discharge the residual pressure in the circuit.

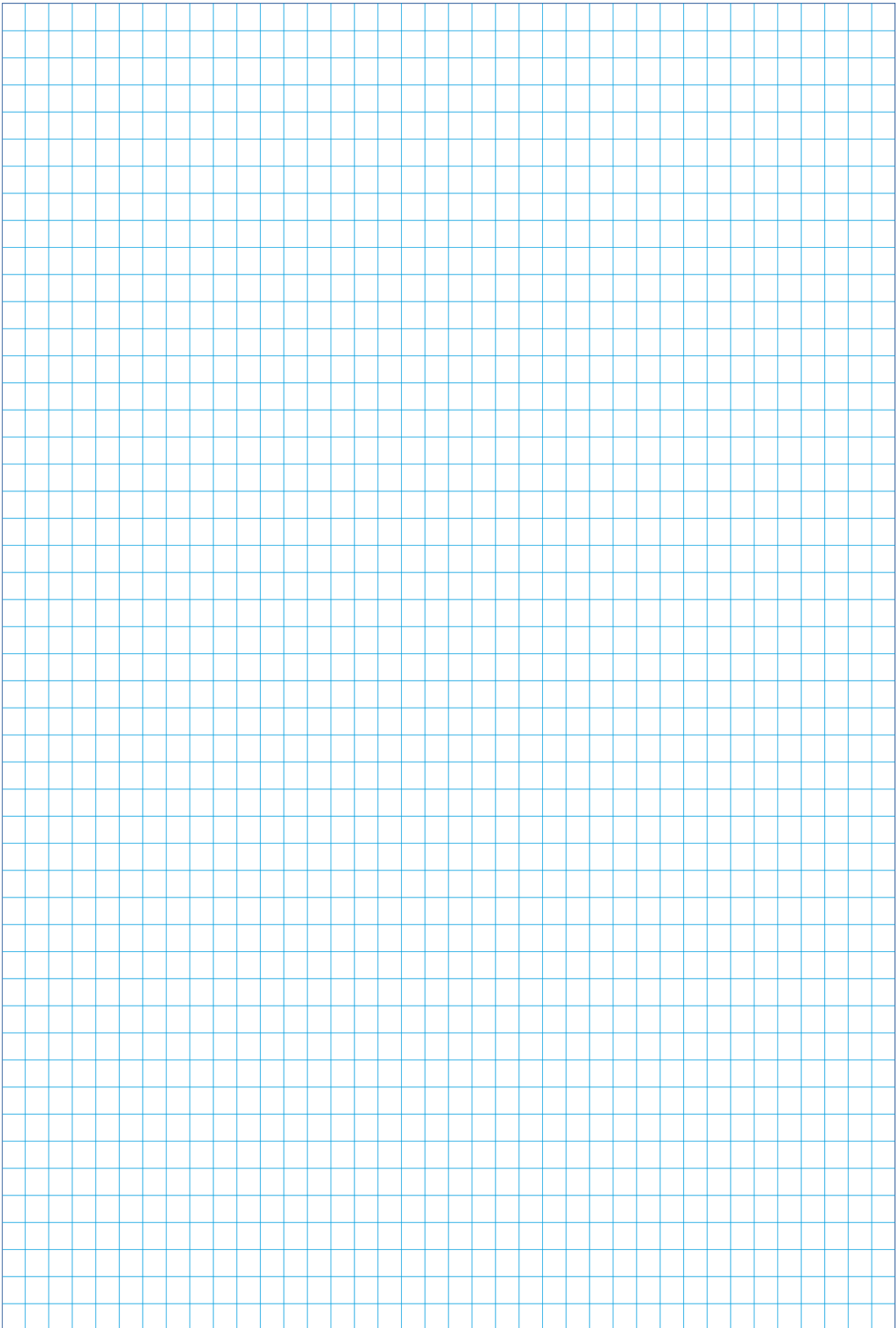

SPARE PARTS

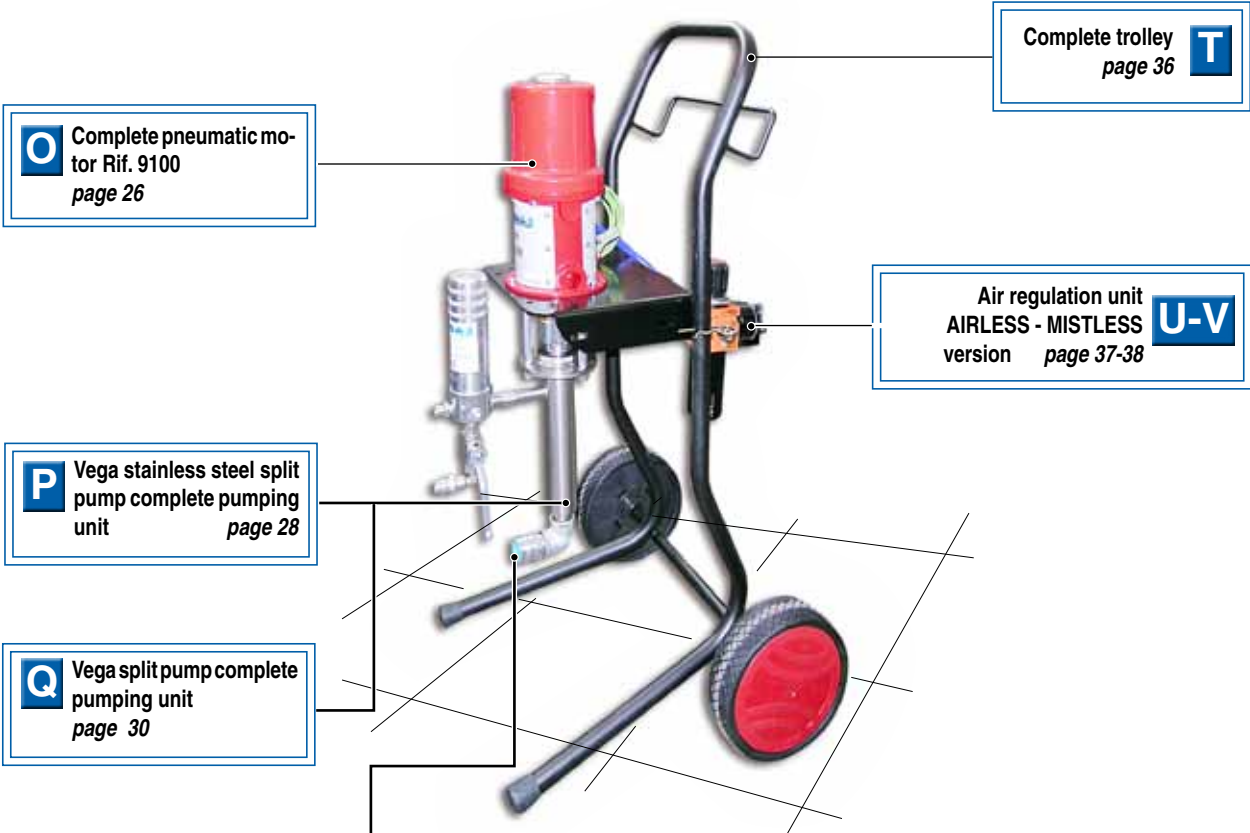

O Complete pneumatic motor Rif. 9100
page 26

Complete trolley **T**
page 36

Air regulation unit AIRLESS - MISTLESS **U-V**
version page 37-38

P Vega stainless steel split pump complete pumping unit
page 28

Q Vega split pump complete pumping unit
page 30

W Paints suction system
page 39



X High pressure gun AT 250
page 40

R Vega split pump on tank complete pumping unit
page 32

S Vega split pump on tank
page 34



VEGA PUMP 23:RIF. 9100 COMPLETE PNEUMATIC MOTOR

ATTENTION: always indicate code and quantity of each requested detail

English

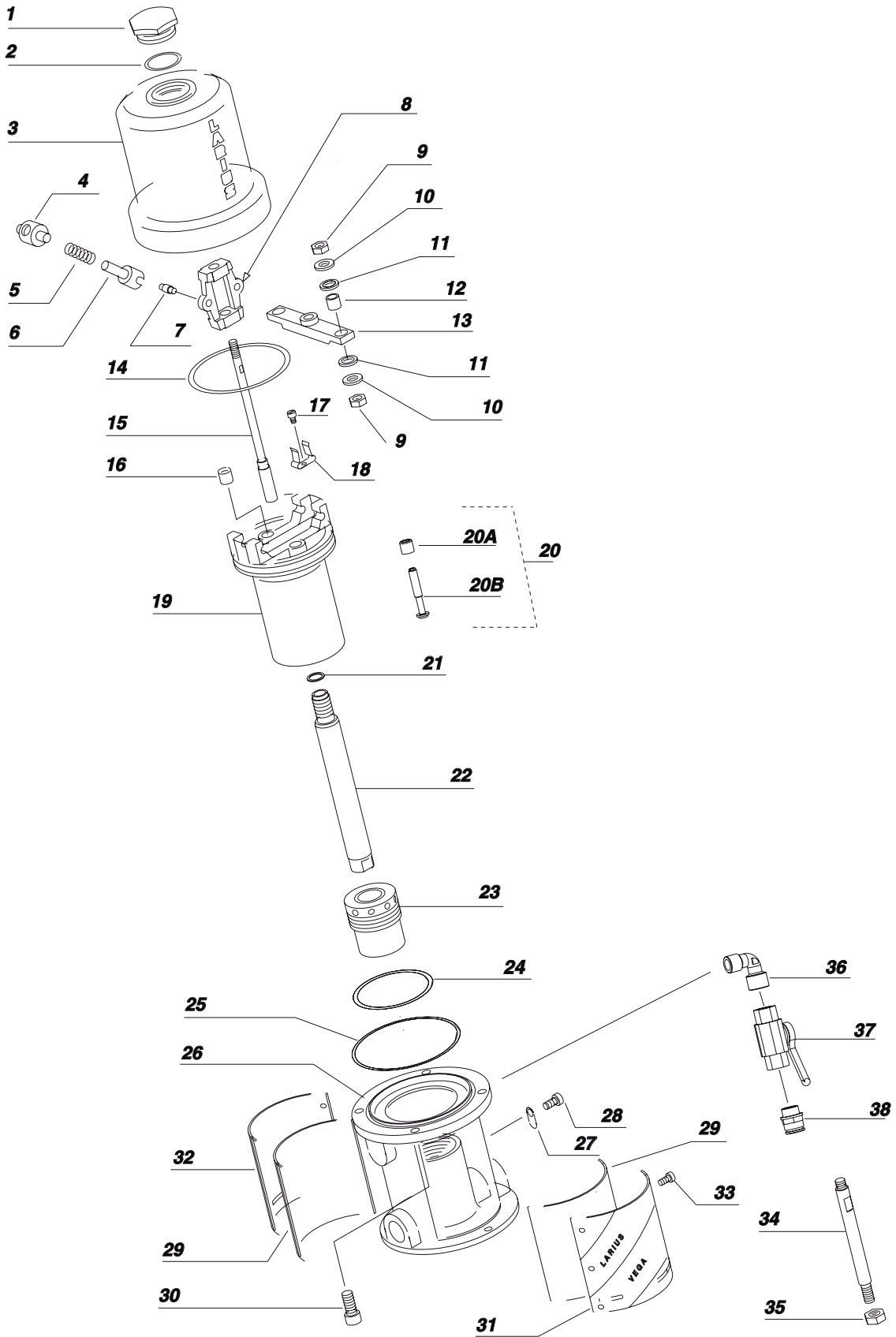

Pos.	Code	Description	Q.ty	Pos.	Code	Description	Q.ty
	91000	Complete pneumatic motor		20A	96014	Rubber valve * **	1
		Vega pump 23:1		20B	96015	Valve screw * **	1
1	96001	Plug	1	21	91036	Washer	1
2	95075	O-Ring	1	22	91043	Piston rod	1
3	91028	Cylinder motor	1	23	96017	Complete washer	1
4	96005	Roller	2	24	91037	O-ring *	1
5	96006	Spring	2	25	91038	O-ring	1
6	96007	Fork	2	26	91042	Motor support	1
7	96024	Fork gudgeon	2	27	96210	Grounding plate	1
8	96008	Rocker lever	1	28	96211	M6 screw	1
9	4108	M8 Nut **	4	29	96340	Felt gasket	2
10	32024	Washer **	4	30	34008	M8 screw	4
11	96111	Gasket * **	4	31	91039	Front label	1
12	96112	Bushing **	2	32	91040	Upper label	1
13	91029	Cross piece	1	33	96028	M4 screw	12
14	91034	O-Ring *	1	34	91006	Tie rod	3
15	91033	Guide	1	35	96080	M10 Nut	3
16	96009	Rubber valve * **	2	36	96214	Elbow 3/8"	1
17	91030	M3 screw	2	37	91101	Ball valve	1
18	91032	Cross piece guide spring	2	38	96215	Quick coupling 3/8" ø 12	1
19	91035	Motor piston	1				
20	96027	Complete valve screw	1				

* Kit 40040: motor gaskets kit

** Kit 40401: cross piece screws kit

**P STAINLESS STEEL SPLIT VEGA PUMP 23:1
COMPLETE PUMPING UNIT**

ATTENTION: always indicate code and quantity of each requested detail.

Complete line filter

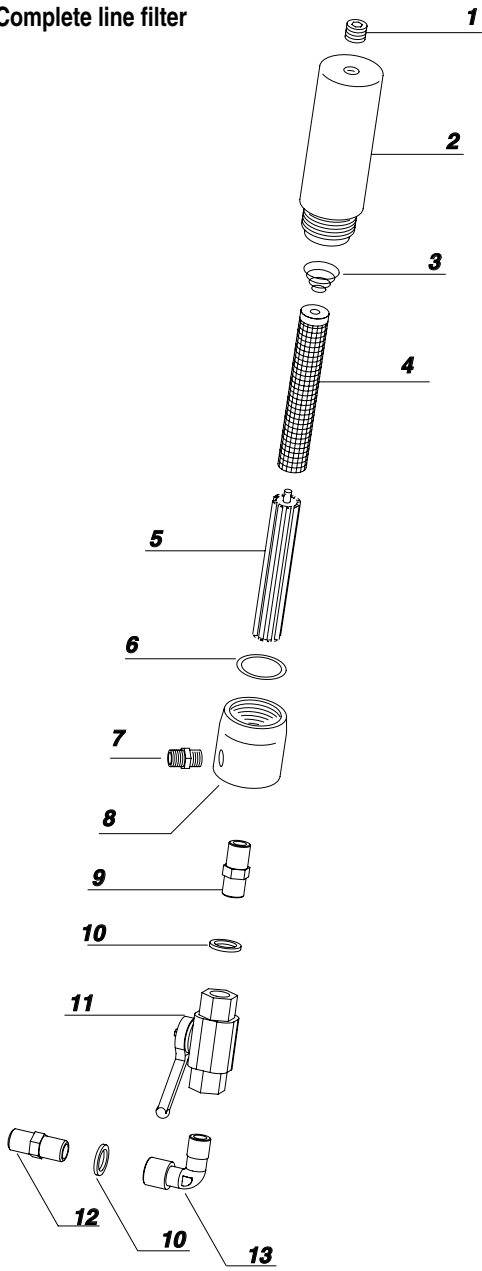

Complete pumping unit

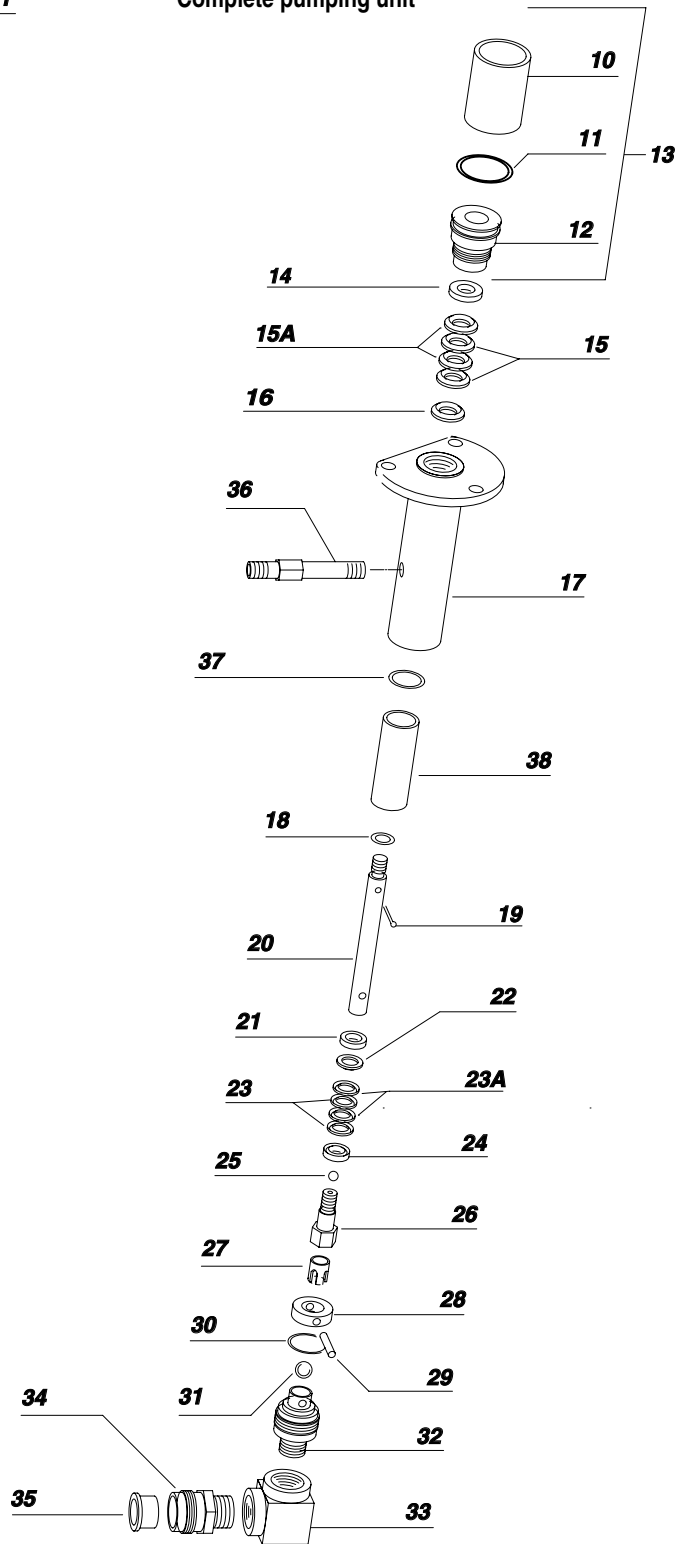

Pos.	Code	Description	Q.ty	Pos.	Code	Description	Q.ty
	98387	Complete line filter		6	96203	O-ring	1
1	98385	3/8" gas plug	1	7	98383	1/4" gas-16x1,5 nipple	1
2	98384	Filter tank	1	8	98380	Filter base	1
3	96202	Sieve spring	1	9	3110	Adapter 1/4" con-cil	1
4	95221	Filter sieve 200m	1	10	32012	Copper gasket 1/4"	2
	95220	Filter sieve 100m	1	11	98325	Ball valve 1/4"	1
	95219	Filter sieve 60m	1	12	98377	Elbow MF 1/4"	1
5	96207	Sieve support	1	13	96065	Adapter 1/4" - M20x2	2

Pos.	Code	Description	Q.ty	Pos.	Code	Description	Q.ty
	98440	Complete pumping unit		*23A	91049	Polyethylene gasket	2
10	91001/1	Oil cup	1	*24	98462	Female V ring	1
11	3429	O-ring	1	*25	96090	Ø5/16* Ball	1
12	98506	Gaskets ring nut	1	26	98463	Pumping unit piston	1
13	91001	Complete cup	1	27	98466	Ball guide	1
*14	98454	Female V ring	1	28	98368	Ring	1
*15	91031	Ptfe gasket	2	29	98370	Ball locking pin	1
*15A	91048	Polyethylene gasket	2	*30	96093	O-ring	1
*16	98456	Male V ring	1	*31	96094	Ø1/2* Ball	1
17	98455	Pumping unit housing	1	32	98373	Suction valve	1
18	91008	O-ring	1	33	98374	Elbow	1
*19	3323	Split pin	1	34	98376	Suction hose fitting	1
20	98452	Piston rod	1	35	96099	Bushing	1
21	98458	Washer	1	36	98378	Filter fitting	1
*22	98460	Male V ring	1	37	96083	Gasket	1
*23	91022	Ptfe gasket	2	38	91512	Liner	1

* Kit 40045: spare kit

Q VEGA SPLIT PUMP 23:1 COMPLETE PUMPING UNIT

ATTENTION: always indicate code and quantity of each requested detail.

Complete line filter

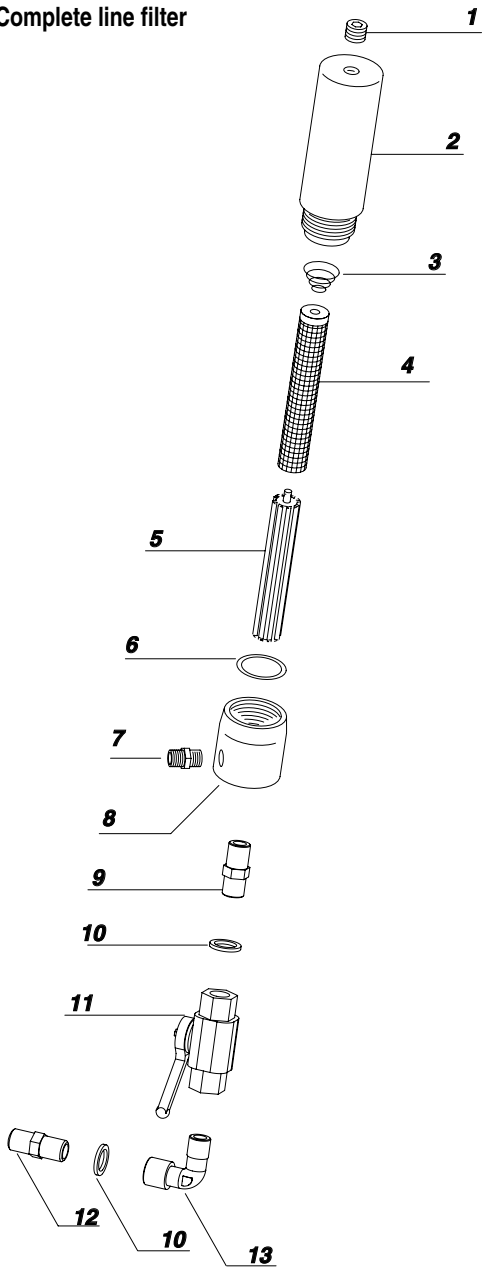

Complete pumping unit

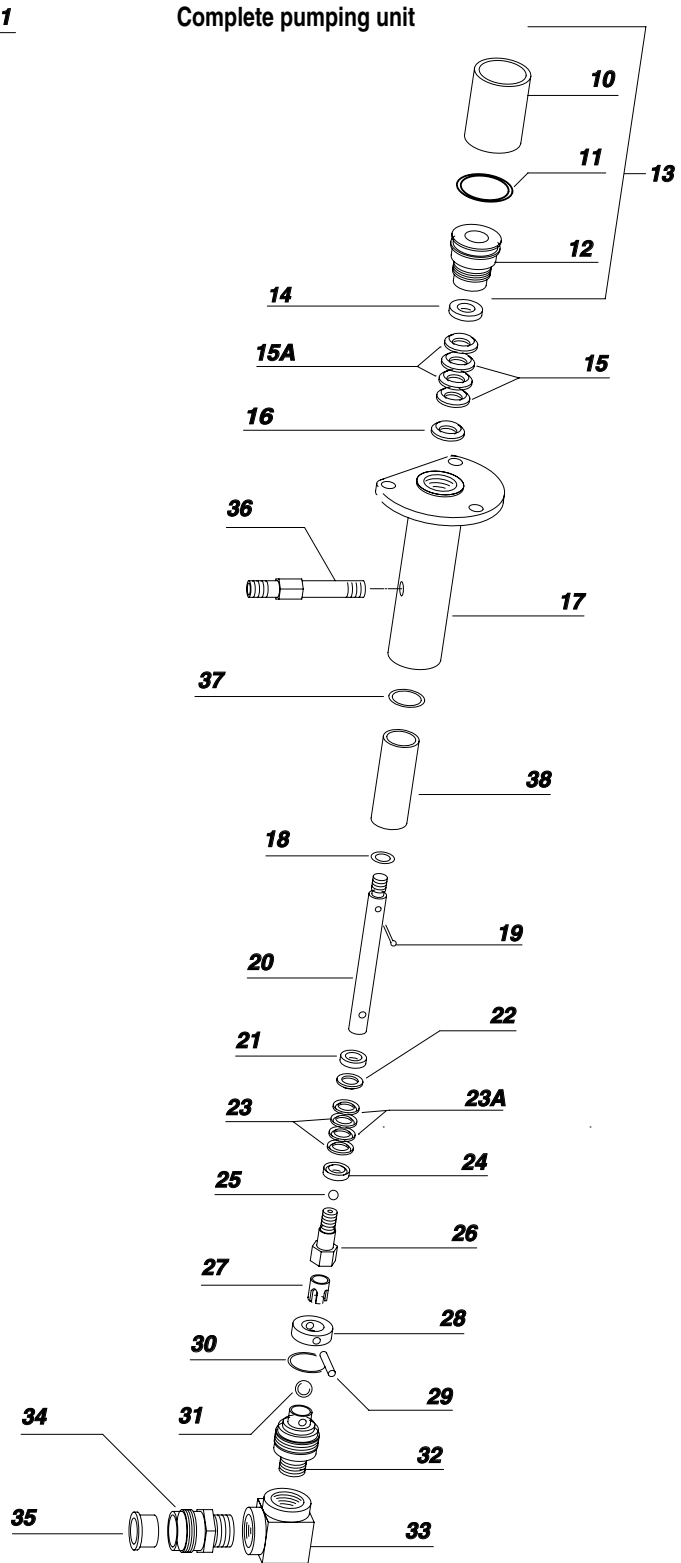

Pos.	Code	Description	Q.ty	Pos.	Code	Description	Q.ty
	96200	Complete line filter		6	96203	O-ring	1
1	95214	3/8" gas plug	1	7	96206	1/4" gas-16x1,5 nipple	1
2	96201	Filter tank	1	8	96204	Filter base	1
3	96202	Sieve spring	1	9	96208	Adapter 1/4" con-cil	1
4	95221	Filter sieve 200m	1	10	33012	Copper gasket 1/4"	2
	95220	Filter sieve100m	1	11	33013	Ball valve 1/4"	1
	95219	Filter sieve 60m	1	12	5255	Elbow MF 1/4"	1
5	96207	Sieve support	1	13	33015	Adapter 1/4" - M20x2	2

Pos.	Code	Description	Q.ty	Pos.	Code	Description	Q.ty
	91027	Complete pumping unit		*23A	91049	Polyethylene gasket	2
10	91001/1	Oil cup	1	*24	98462	Female V gasket	1
11	3429	O-ring	1	*25	96090	Ø5/16* ball	1
12	98506	Gaskets ring nut	1	26	98463	Pumping unit piston	1
13	91001	Complete cup	1	27	91714	Ball guide	1
*14	98454	Female V ring	1	28	96092	Ring	1
*15	91031	Teflon gasket	2	29	98370	Ball locking pin	1
*15A	91048	Polyethylene gasket	2	*30	96093	O-ring	1
*16	98456	Male V ring	1	*31	96094	Ø1/2* ball	1
17	98455	Pumping unit housing	1	32	98373	Suction valve	1
18	91008	O-ring	1	33	95089	Elbow	1
*19	3323	Split pin	1	34	96098	Suction hose fitting	1
20	98452	Piston rod	1	35	96099	Entry liner	1
21	98458	Washer	1	36	98378	Filter fitting	1
*22	98460	Male V ring	1	37	96083	Gasket	1
*23	91022	Teflon gasket	2	38	91512	Liner	1

* Kit 40045: spare kit

R VEGA SPLIT PUMP ON TANK 23:1 COMPLETE PUMPING UNIT

ATTENTION: always indicate code and quantity of each requested detail.

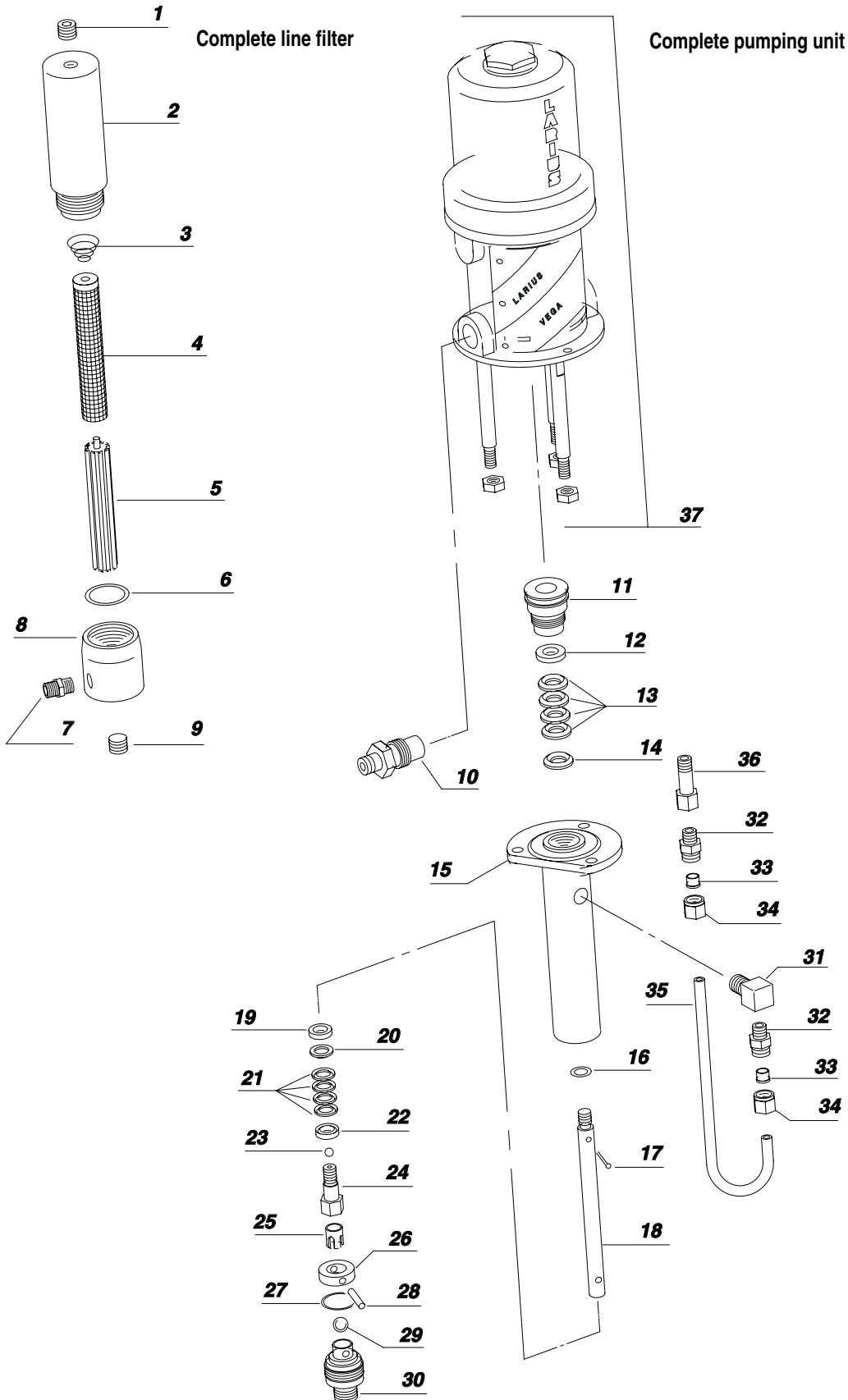

Pos.	Code	Description	Q.ty
	96200	Complete line filter	
1	95214	3/8" gas plug	1
2	96201	Filter tank	1
3	96202	Sieve spring	1
4	95221	Filter sieve 200m	1
	95220	Filter sieve 100m	1
	95219	Filter sieve 60m	1
5	96207	Sieve support	1
6	96203	O-ring	1
7	96206	1/4" gas-16x1,5 nipple	1
8	96204	Filter base	1
9	96205	1/4" gas plug	2

Pos.	Code	Description	Q.ty	Pos.	Code	Description	Q.ty
	91710	Complete pumping unit		22	91013	Female V ring	1
10	91730	Filter fitting	1	*23	96090	Ø5/16* ball	1
11	91001/2	Gaskets ring nut	1	24	91017	Pumping unit piston	1
12	91002	Female V ring	1	25	91714	Ball guide	1
*13	91003	Teflon gasket (standard)	4	26	96092	Ring	1
13A	91004	Leather gasket	1	*27	96093	O-ring	1
14	91005	Male V ring	1	28	96096	Ball locking pin	1
15	91007	Pumping unit housing	1	*29	96094	Ø1/2* ball	1
16	91008	O-ring	1	30	91713	Suction valve	1
*17	3323	Split pin	1	31	91712	Fitting	1
18	91009	Piston rod	1	32	91715	Fitting	2
19	91011	Washer	1	33	91716	Hub	2
20	91012	Male V ring	1	34	91717	Hub nut	2
		Teflon and glass gasket (standard)	4	35	91718	Product tube	1
*21	91014	Pure Teflon gasket	1	36	91719	Fitting (3 leather 1 teflon)	1
21A	91022	Leather gasket	1	37	91000	Complete pneumatic motor	

* Kit 40045: spare kit

S VEGA SPLIT PUMP 23:1 ON TANK RIF. 91700

ATTENTION: always indicate code and quantity of each requested detail.

English

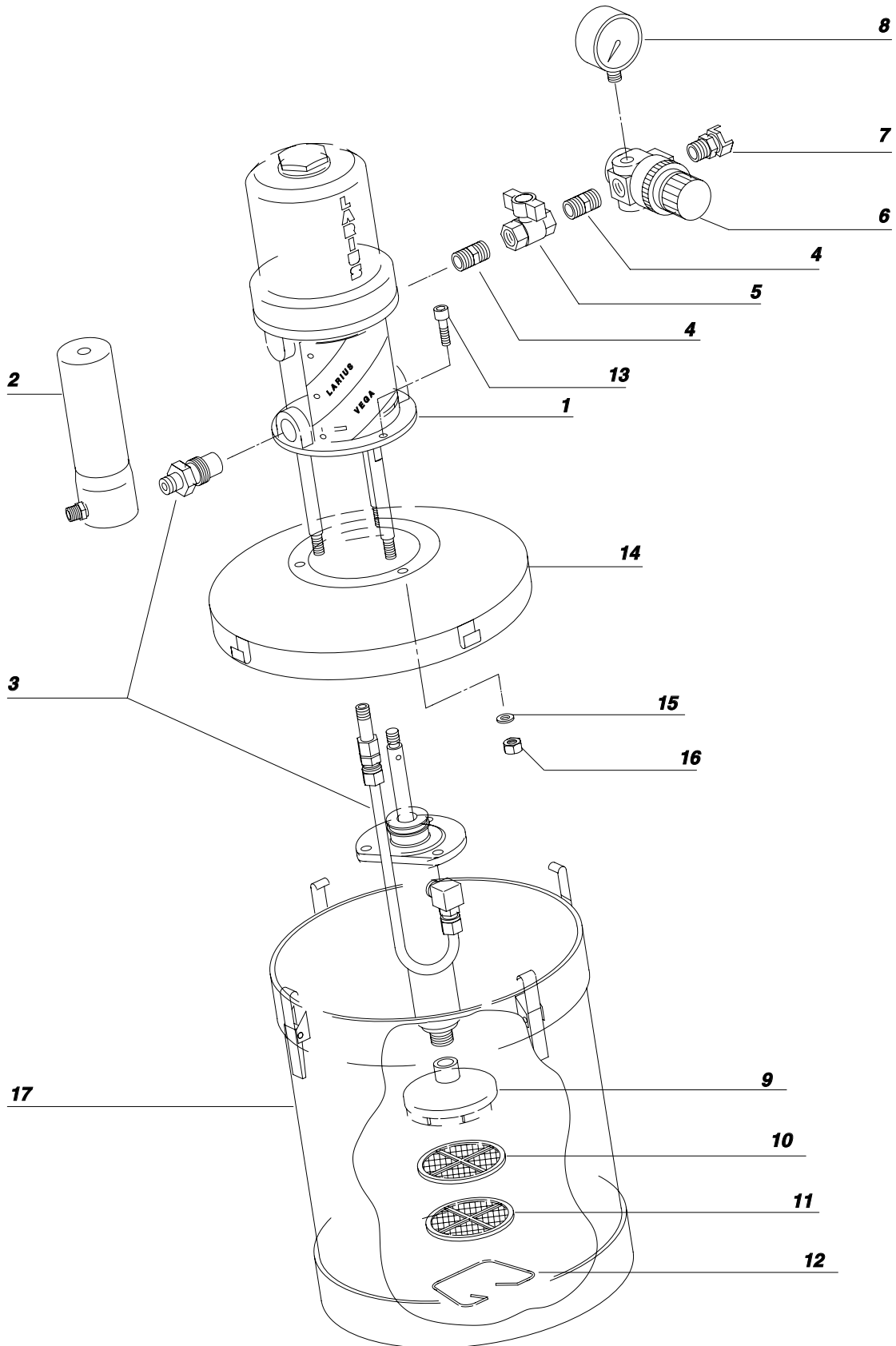

Pos.	Code	Description	Q.ty
1	91000	Complete pneumatic motor	1
2	96200	Complete line filter	1
3	91710	Complete pumping unit	1

Pos.	Code	Description	Q.ty
	91735	Complete air regulation unit	
4	91020	3/8" gas C nipple	2
5	91101	3/8" gas tap	1
6	91736	Pressure regulator	1
7	10103	Bajonet coupling	1
8	96259	Pressure gauge	1

Pos.	Code	Description	Q.ty
	91725	Complete tank filter	
9	91726	Filter tank	1
10	35006	Fine-mesh filter disc	1
11	35007	Large-mesh filter disc	1
12	35008	Spring	1

Pos.	Code	Description	Q.ty
	91740	Complete container	
13	91062	M6 screw	3
14	91721	Container cover	1
15	54003	Washer	3
16	91026	M6 Nut	3
17	91743	Container	1

T COMPLETE TROLLEY

ATTENTION: always indicate code and quantity of each requested detail.

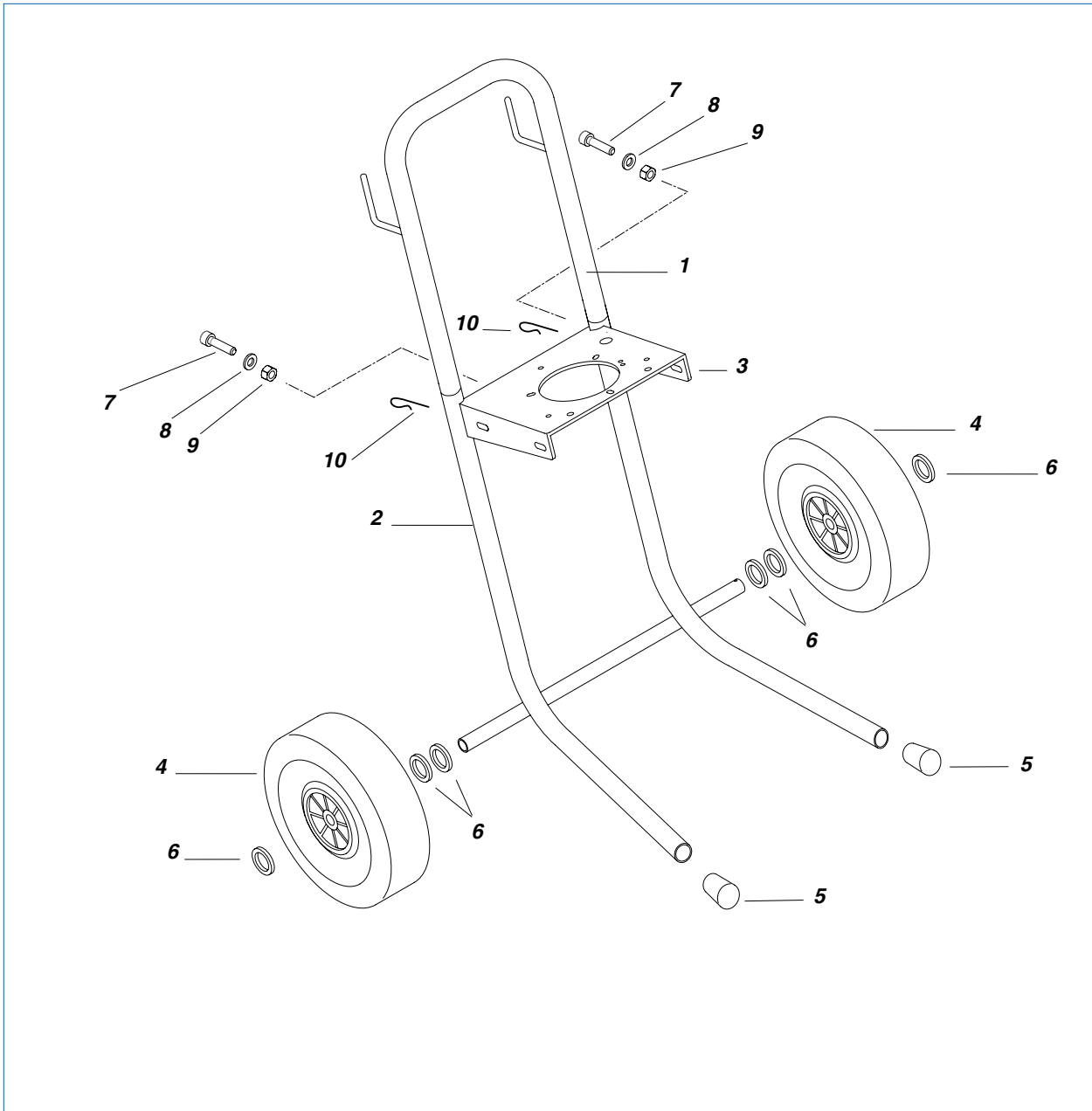

Pos.	Code	Description	Q.ty	Pos.	Code	Description	Q.ty
	96320	Complete trolley		6	91047	Wheel washer	6
1	16271	Trolley handle	1	7	8047	Screw	2
2	16272	Trolley frame	1	8	95063	Washer	2
3	16954	Trolley plate	1	9	91026	Nut	2
4	91023	Wheel	2	10	84007	Split pin	2
5	37403	Feet	2				

U AIRLESS VERSION Rif. 96250 AIR REGULATION UNIT

ATTENTION: always indicate code and quantity of each requested detail

English

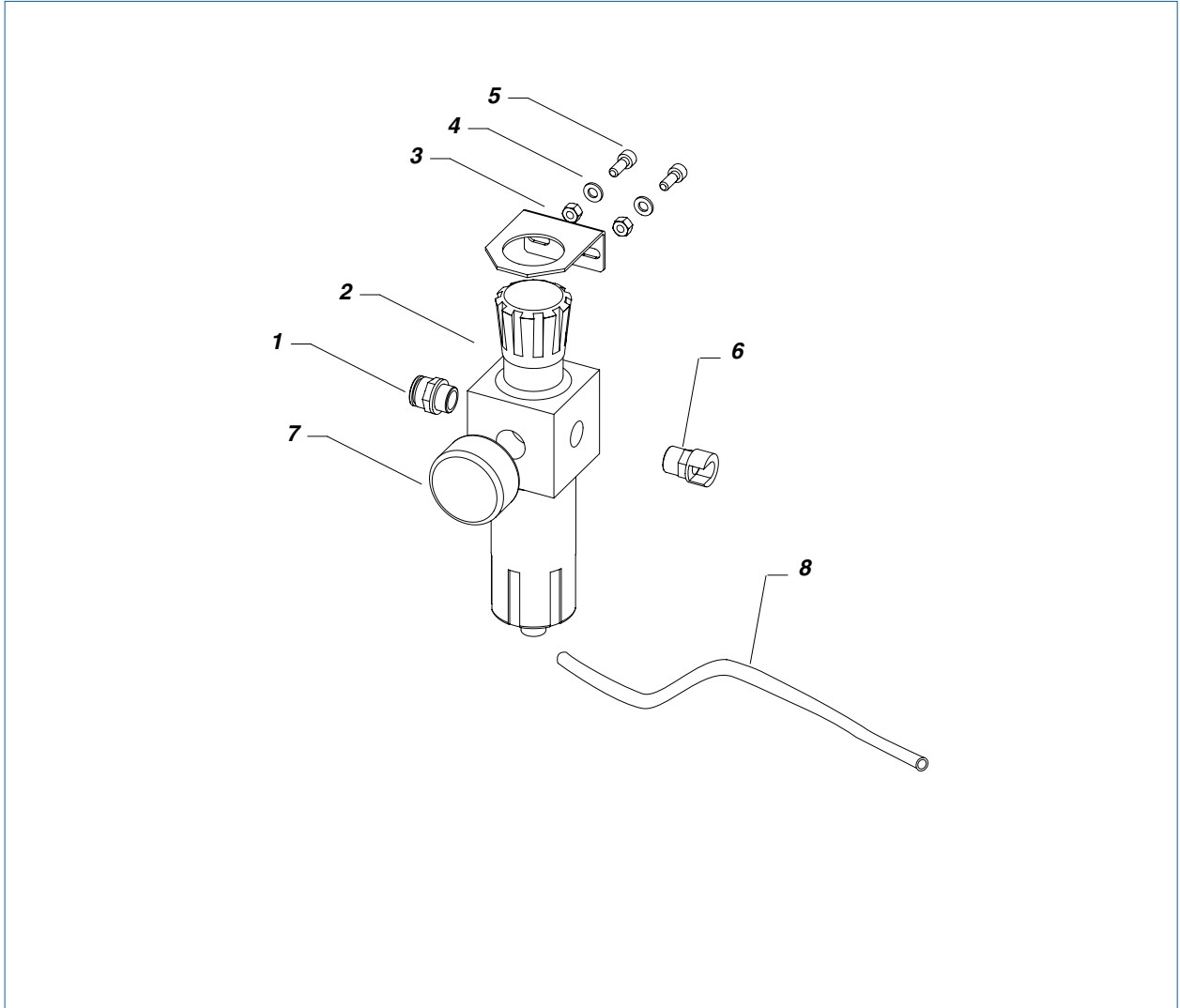

Pos.	Code	Description	Q.ty	Pos.	Code	Description	Q.ty
	96250	Complete unit	-	5	8047	TCE UNI 5931 M6x22 screw	2
1	96015	3/8 tube Ø 12 quick coupling	1	6	10103	Bajonet coupling	1
2	91107	FR group	1	7	96259	Pressure gauge	1
3	91026	UNI 5588 M6 Nut	2	8	96217	Rilsan tube	1
4	95063	Ø 6 washer	2				

V MISTLESS VERSION Rif. 96262 AIR REGULATION UNIT

ATTENTION: always indicate code and quantity of each requested detail.

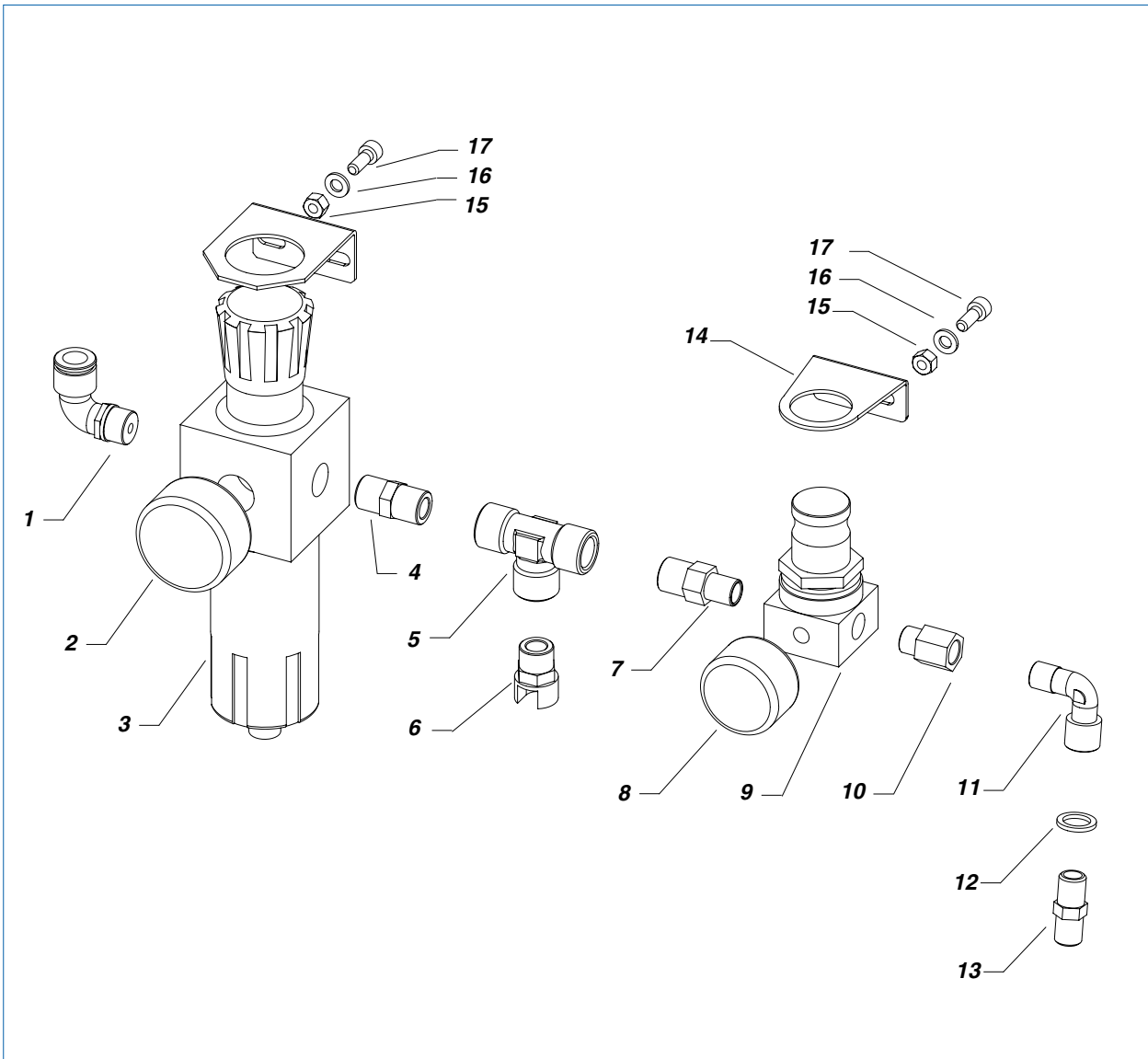

Pos.	Code	Description	Q.ty	Pos.	Code	Description	Q.ty
	96262	Complete unit	-	9	3344	Air regulator	1
1	96216	3/8 tube Ø 12 quick coupling	1	10	8055/1	1/4 MF adapter	1
2	96259	Pressure gauge	1	11	5255	MF 1/4 elbow	1
3	91107	Group RL 3/8 + bracket	1	12	33012	1/4 cupper gasket	1
4	91020	3/8 mm conic adapter	1	13	3289	1/4 mm adapter	1
5	3379	3/8 "T" female fitting	1	14	510510	Pressure gauge bracket	1
6	10103	Bajonet coupling	1	15	91026	UNI 5588 M6 nut	2
7	3560	3/8 1/4 mm CON-CON adapter	1	16	95063	Ø 6 washer	2
8	8167	Pressure gauge	1	17	8047	TCE UNI5931 M6x22 screw	2

W PAINTS SUCTION SYSTEM

ATTENTION: always indicate code and quantity of each requested detail.

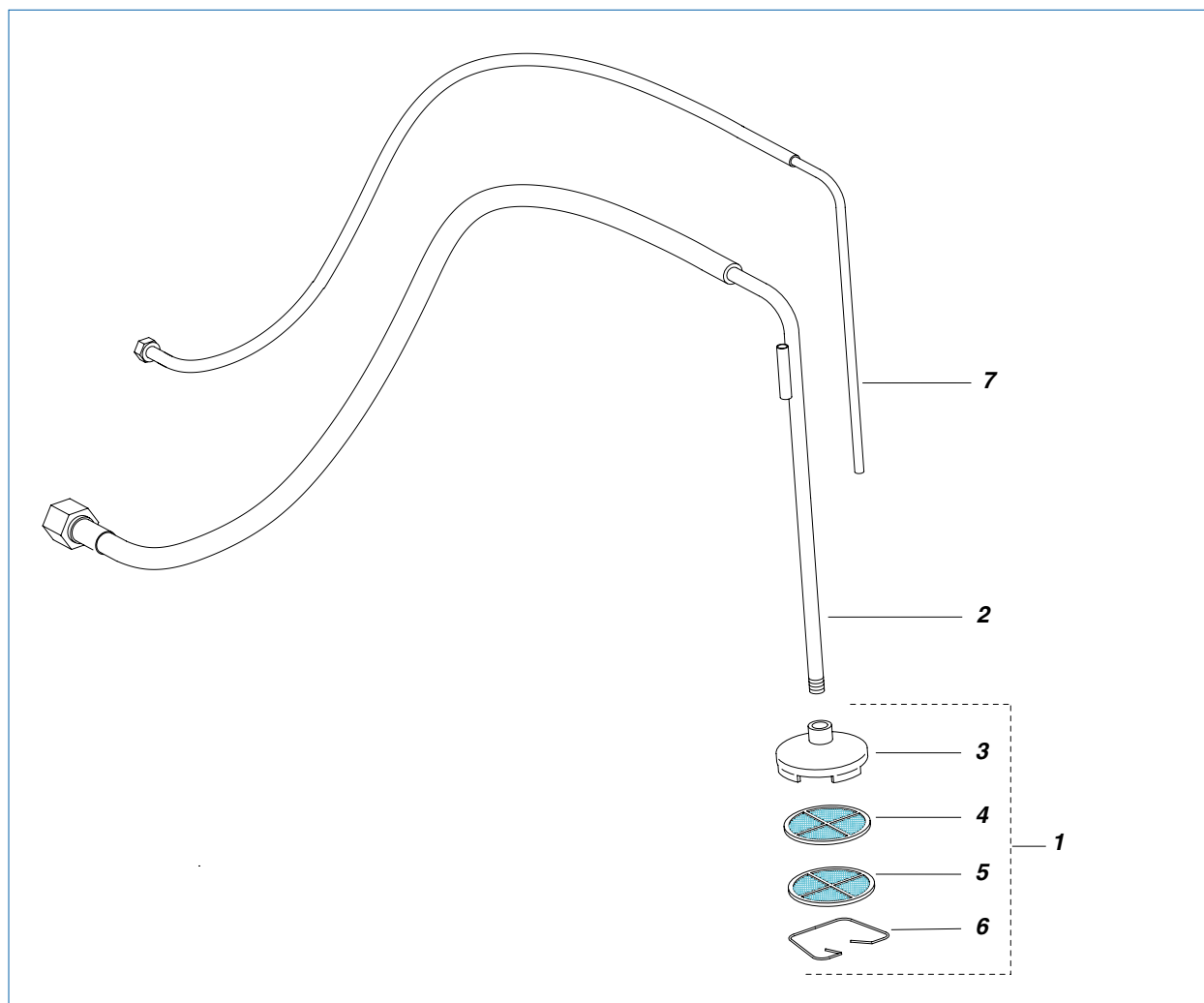

Pos.	Code	Description	Q.ty	Pos.	Code	Description	Q.ty
	16110	Paints suction system with split suction tubes			16111	Paints suction system with stainless steel suction tubes	
1	35020	Filter assembly	1	1	35020	Assieme filtro di fondo	1
2	16608	Suction hose complete with filter with split suction unit	1	2	16612	Suction hose complete with filter with split suction unit	1
3	35005/1	Filter tank	1	3	35005/1	Filter tank	1
4	35006	Thin filter disc (80 mesh)	1	4	35006	Thin filter disc (80 mesh)	1
5	35007/1	Thick filter disc (25 mesh)	1	5	35007/1	Thick filter disc (25 mesh)	1
6	35008	Spring	1	6	35008	Spring	1
7	16609	Split recirculation tube	1	7	16613	Split recirculation tube	1

X AT 250 HIGH PRESSURE GUN

ATTENTION: always indicate code and quantity of each requested detail.

English

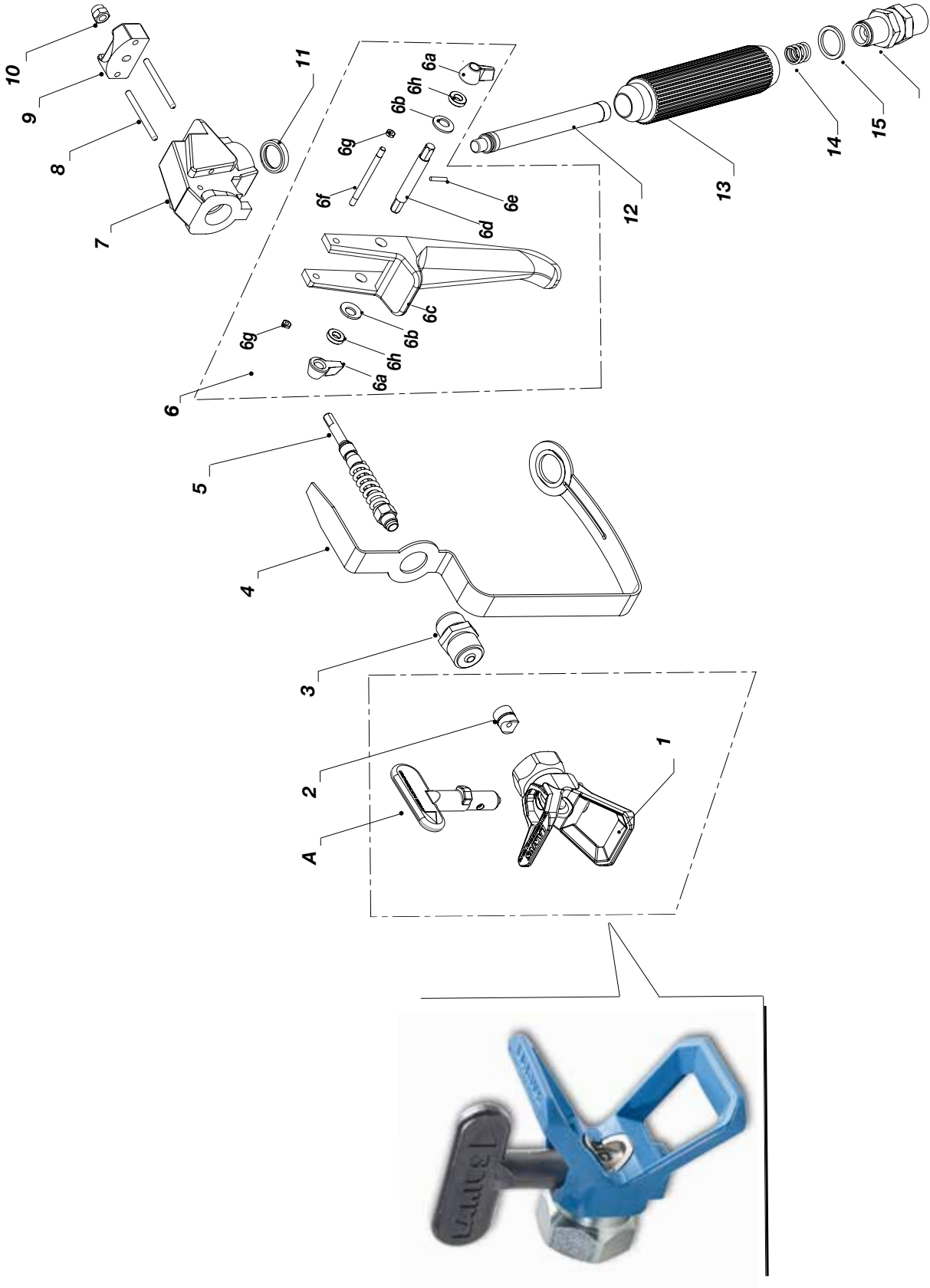

Pos.	Code	Description	Pos	Code	Description
A	See table*	Nozzle Super Fast Clean	6g	11027	Nut M3
1	18270	Body Super Fast Clean	6h	11016	Washer
2	18280	Gasket Super Fast Clean	7	11206	Gun body
3	11004	Sleeve	8	11207	Spinnet
4	11006 +	Safety for hand +	9	11208	Plate
	11032	3 screws TSP 3x8	10	11209	Self-locking nut M5
5	11203	Complete linkage	11	11020	Copper gasket
6	11008	Trigger gun	12	-	Filter
6a	11010	Safety lever	13	11018	Handgrip
6b	11011	Brake washer	14	11017	Spring
6c	11009	Trigger	15	32010	Copper gasket
6d	11012	Pin	16	11015	Articulated joints M16x1,5
6e	11013	Pin		11155	Articulated joints 1/4"
6f	11034/1	Pin			

Components Pos. 5 - 11023 - Linkage

11005/3	Ball
11204/1	Ball housing
11205/2	Spring
11205/4	Linkage
11205/5	Sleeve
11205/6	Ring sleeve
11205/7	Bushing

Y ACCESSORIES

English



Art. 11250: AT 250 1/4"
Art. 11200: AT 250 M16x1,5



GUN FILTERS
Art. 11039: Green (30M) - **Art. 11038:** White (60M)
Art. 11037: Yellow (100M) - **Art. 11019:** Red (200M)



FILTER
Art. 95218: SIEVE 30M
Art. 95219: SIEVE 60M
Art. 95220: SIEVE 100M
Art. 95221: SIEVE 200M



FITTING WITH PRESSURE GAUGE
Art. 147: M16x1,5
Art. 150: 1/4"

SUPER FAST-CLEAN

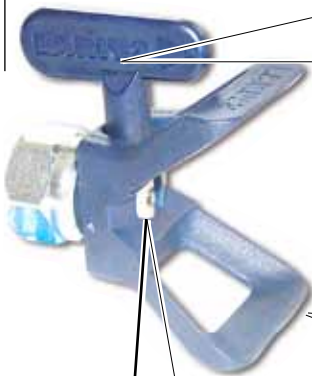

SUPER FAST-CLEAN NOZZLE

Nozzles codes		
SFC07-20	SFC19-60	SFC29-80
SFC07-40	SFC21-20	SFC31-40
SFC09-20	SFC21-40	SFC31-60
SFC09-40	SFC21-60	SFC31-80
SFC11-20	SFC23-20	SFC33-40
SFC11-40	SFC23-40	SFC33-60
SFC13-20	SFC23-60	SFC33-80
SFC13-40	SFC25-20	SFC39-40
SFC13-60	SFC25-40	SFC39-60
SFC15-20	SFC25-60	SFC39-80
SFC15-40	SFC27-20	SFC43-40
SFC15-60	SFC27-40	SFC43-60
SFC17-20	SFC27-60	SFC43-80
SFC17-40	SFC27-80	SFC51-40
SFC17-60	SFC29-20	SFC51-60
SFC19-20	SFC29-40	SFC51-80
SFC19-40	SFC29-60	

Art. 18280: GASKET



Art. 18270: SUPER FAST-CLEAN base UE 11/16x16



GUN EXTENSION

Art. 153: cm 30 - Art. 153: cm 40

Art. 155: cm 60 - Art. 158: cm 80 - Art. 156: cm 100

Art. 96200: LINE FILTER galvanized
Art. 98387: LINE FILTER stainless steel

Art. 16610: SUCTION SYSTEM

Art. 16611: SUCTION SYSTEM stainless steel



ANTISTATIC TUBE 3/16" - M16x1,5 max pressure 210 bar

Art. 6164: 5 mt

Art. 55050: 7,5 mt

Art. 35018: 10 mt



ANTI-PULSE TUBE 1/4" - M16x1,5 max pressure 250 bar

Art. 35013: 5 mt

Art. 35014: 7,5 mt

Art. 35017: 10 mt

Art. 18026: 15 mt



HIGH PRESSURE TUBE 3/8" - M16x1,5 max pressure 425 bar

Art. 18063: 7,5 mt

Art. 18064: 10 mt

Art. 18065: 15 mt

Z VERSIONS



Rif. 91500: VERSION ON TROLLEY

Vega ratio 23:1 without working kit	
Code	DESCRIPTION
91500	Vega 23:1 on trolley
91504	Vega 23:1 stainless steel on trolley
91700	Vega 23:1 on tank
91900	Vega 23:1 on wall bracket
91905	Vega 23:1 stainless steel on wall bracket

Pump complete with line filter, discharge valve, suction, recirculation system.



Rif. 91700: VERSION ON TANK



Rif. 91900: VERSION ON WALL BRACKET

Working kit	
Code	DESCRIPTION
55050	High pressure tube Ø 3/16" coupled M16X1,5 mt 7,5
11200	Airless gun AT 250 revolving coupling M16X1,5 including Super fast clean base Rif. 18270 as option: Rif. 11250 airless gun AT250 revolving coupling ¼" including Super fast clean base Rif. 18270
18270	Super fast clean base
SFC	"Super fast clean nozzle from 0.007" to 0,051"

It is possible to use standard nozzles.

Vega ratio 23:1 complete with working kit. Nozzle not included.	
Code	DESCRIPTION
k91506	Vega 23:1 Version on trolley + accessories complete with FRL and drain valve
91500	Vega with line filter, suction-recirculation system
55050	High pressure tube Ø 3/16" coupled M16X1,5 mt 7,5
11200	Airless gun AT250 revolving coupling m16x1,5
18270	Super fast clean base
K91508	Vega 23:1 stainless steel Version on trolley + accessories complete with FRL and drain valve
91504	Vega with line filter, suction-recirculation system
55050	High pressure tube Ø 3/16" coupled M16X1,5 mt 7,5
11200	Airless gun AT250 revolving coupling m16x1,5
18270	Super fast clean base
K91510	Vega 23:1 Version on tank + accessories complete with FRL and drain valve
91700	Vega with line filter, suction-recirculation system
55050	High pressure tube Ø 3/16" coupled M16X1,5 mt 7,5
11200	Airless gun AT250 revolving coupling m16x1,5
18270	Super fast clean base

KIT	
Code	DESCRIPTION
40005	AT 250 Airless gun kit
40400	AT 250 Airless gun filters
40026	AT 250 Trigger kit
40045	Vega 23:1 gaskets kit
40040	Vega 23:1 motor kit
40401	Vega 23:1 bar screws kit

ATEX CERTIFICATION

SAFETY INSTRUCTIONS FOR THE USE OF PISTON PNEUMATIC TRANSFER PUMPS VEGA SERIES IN POTENTIALLY EXPLOSIVE ENVIRONMENTS IN PRESENCE OF GAS OR VAPOURS.

AA DESCRIPTION

This safety instructions refer to the installation, use and maintenance of LARIUS piston pneumatic transfer pumps VEGA series for the use in potentially explosive areas in presence of gas or vapours.



These instructions should be followed in addition to the instructions provided in the use and maintenance manual.

LARIUS piston pneumatic transfer pumps VEGA series are mechanical equipment belonging to group II, for the use in areas in presence of gas which are classified as IIB (category 2 G). They have been designed and manufactured in compliance with the directive ATEX 94/9/CE, according to european standards EN 1127-1, EN 13463-1 ed EN 13463-5.



AB TECHNICAL FEATURES

The main characteristics of piston pneumatic transfer pumps VEGA serie are indicated in the table below:

Type		Ratio	Supplied pressure	Ø Air inlet	Ø product feeding	Ø product outlet	max operat. pressure	max rate
Standard	St. steel							
91360	91362	5:1	3 ÷ 8 bar	GC 3/8"	Ball valve	GC 3/4"	40 bar	10 l/min
91365	91361	5:1	3 ÷ 8 bar	GC 3/8"	Ball valve	GC 3/4"	40 bar	10 l/min
91368	91363	5:1	3 ÷ 8 bar	GC 3/8"	Ball valve	GC 3/4"	40 bar	10 l/min
91501	91503	23:1	3 ÷ 8 bar	GC 3/8"	Ball valve	GC 3/8"	184 bar	2,6 l/min
91910	-	45:1	3 ÷ 8 bar	GC 3/8"	Washer	GC 3/8"	360 bar	1 l/min
91911	-	45:1	3 ÷ 8 bar	GC 3/8"	Washer	GC 3/8"	360 bar	1 l/min
91912	-	45:1	3 ÷ 8 bar	GC 3/8"	Washer	GC 3/8"	360 bar	1 l/min

Max number of cycles per minute: 60

Room temperature: -20°C ÷ +60°C

Fluid max temperature: [°C]: 60°C

AC MARKING

CE  II 2 G c IIB T6 T_{amb}: -20°C ÷ + 60°C T_{max. fluid}: 60°C Tech. File: VEGA/ATX/08

II	Group II (surface)
2	Grade 2 (zone 1)
G	Explosive environment with gas, vapour or mist
c	Constructive safety "c"
T6	Class of temperature T6
- 20°C ÷ + 60°C	Room temperature
60°C	Max temperature of process fluid
xxxxx/AA	Series number or lot number (xxxxx = PROGRESSIVE / year = AA)

Correspondence between dangerous areas, substances and grade

DANGEROUS AREA		GRADE ACCORDING TO DIRECTIVE 94/9/CE
Gas, vapour or mist	Area 0	1G
Gas, vapour or mist	Area 1	2G or 1G
Gas, vapour or mist	Area 2	3G, 2G or 1G

AD SAFETY INSTRUCTIONS FOR THE INSTALLATION IN DANGEROUS AREAS

Before installation please read carefully the use and maintenance manual. All maintenance operations must be carried out as reported in the manual.



- The grounding cable of these pumps must be connected by means of suitable electrical connector.
- The feeding and suction hoses should be metal pipes, or plastic pipes with metal braid or plastic pipes with textile braid equipped with a suitable grounding conductor.
- Pumps must be installed on containers made of metal or antistatic material, duly grounded.
- Gas or vapour rising from flammable liquids shall belong to the group IIB.

- The user must periodically control the presence of foulings, the cleaning and wear conditions and the proper operation of the pump, according to the type and use of the product

- The user should periodically clean the suction filter in order to prevent foreign matters entering into the pump. The air used to supply power to the pump must be filtered and come from a safe area (*SAFE AREA*).



The pneumatic piston pumps VEGA series must not run dry.



All installation and maintenance operations must be performed by qualified personnel.

AE EXAMPLE OF INSTALLATION



The picture shows a typical example of installation of a piston transfer pneumatic pump.

AF DECLARATION OF CONFORMITY

We Larius S.r.l.
Via Stoppani, 21
23801 Calolziocorte (LC)

declare under our sole responsibility that the product:

Piston transfer pneumatic pumps VEGA series.

,this declaration is referred to, complies to the following directive:

- **Directive 94/9/EC (ATEX)**

Compliance has been verified on the basis of the requirements provided by the following rules and documents:

- EN 1127-1 - EN 13463-5
- EN 13463-1

Marking

CE & II 2 G c IIB T6 Tamb.: - 20°C ÷ 60°C Tmax. fluid: 60°C
Technical dossier: VEGA/ATX/08
Technical dossier c/o: INERIS (0080)

Calolziocorte- LC, 15/12/2008

Signature (LARIUS)

LARIUS

PAINT SPRAYING EQUIPMENT

*L'innovazione.
Quella vera.*

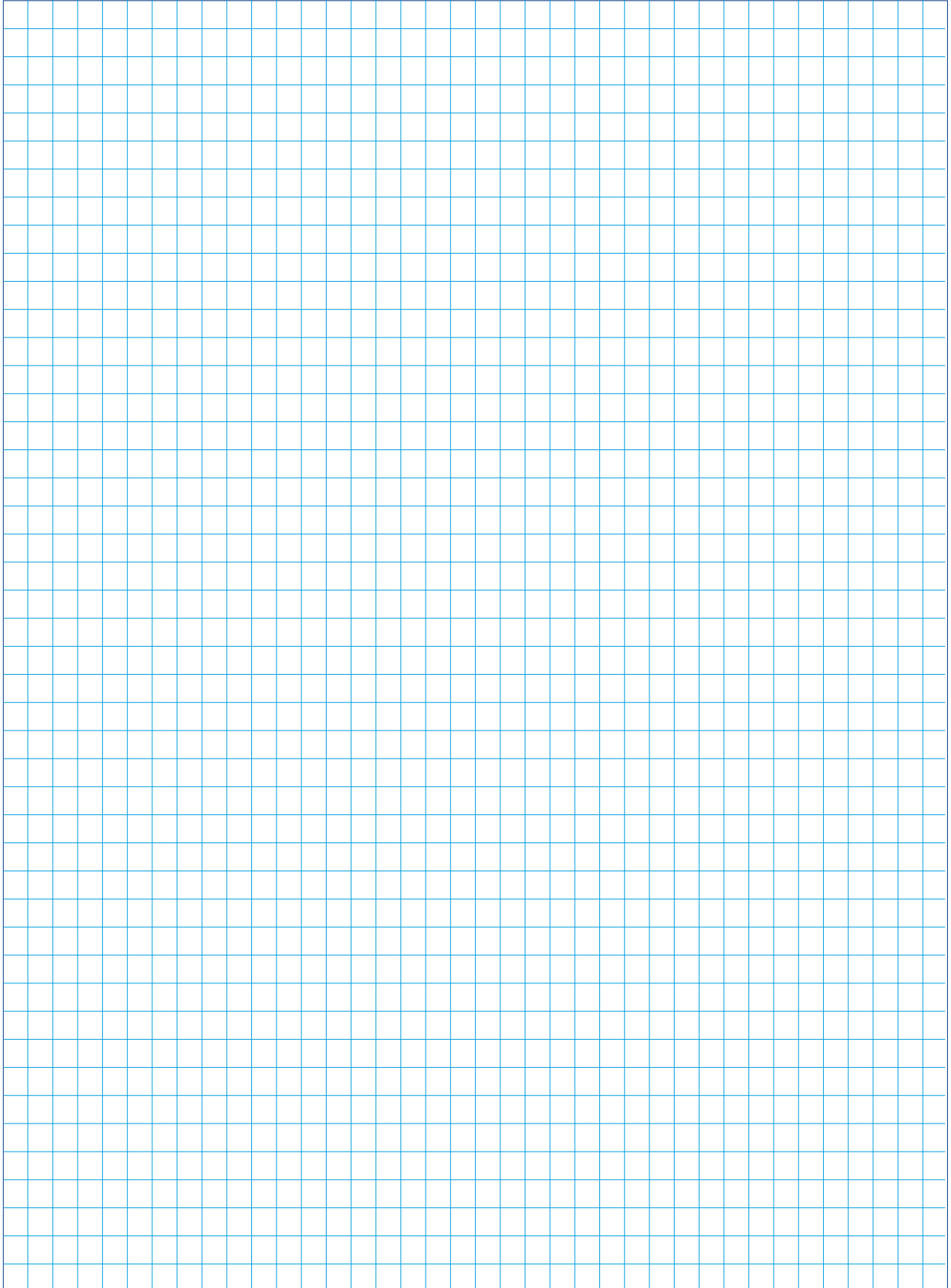

AIRLESS PNEUMATIC PUMPS

OMEGA AIRLESS Art.-Nr. 7300
OMEGA MISTLESS Art.-Nr. 7340



OMEGA ZINC Rif. 7430

NOVA Rif. 95040



SUPERNOVA 45:1 Rif. 65100
SUPERNOVA 68:1 Rif. 65102
SUPERNOVA 80:1 Rif. 65104



GHIBLI ZINC Rif. 96900

GHIBLI 30:1 Art.-Nr. 96000



GHIBLI MIX 2K 40:1 INOX: Rif. 24561

MANUFACTURER:

LARIUS

23801 CALOLZIOCORTE - LECCO - ITALY - Via Antonio Stoppani, 21
Tel. (39) 0341/62.11.52 - Fax (39) 0341/62.12.43
E-mail: larius@larius.com - Internet <http://www.larius.com>



CUSTOMERS TECHNICAL SERVICE

Tel. (39) 0341/621256
Fax (39) 0341/621234

